

HOME LABORATORY EXPERIMENT NO. 7

Section 7A

THE SUPERHETERODYNE RECEIVER

Practically all modern radio and television receivers employ the super heterodyne circuit. This circuit is employed since it provides a high degree of uniform selectivity over the entire tuning range and also has a high degree of sensitivity. To have a thorough knowledge, an electronics technician must have a good practical understanding of the operation of super heterodyne receivers as well as a theoretical understanding of the operation. In this Home Laboratory Experiment a complete superheterodyne receiver will be constructed, providing you with the opportunity of gaining the necessary practical experience in working with superheterodyne receivers.

The theoretical manner in which a superheterodyne receiver operates is explained in detail in Assignment 36. In addition, a number of the assignments following that one are based upon superheterodyne receivers. If you are not completely familiar with superheterodyne receivers, the theoretical assignments covering the subject should be reviewed.

PRECAUTION

- The 110-volt AC line will be connected to this receiver and the high-voltage power supply will be used. For this reason, the precautions which should be observed when working on either type of circuit should be observed at all times when working on the receiver. Always make sure that the a-c power is turned off before making circuit changes.

Parts and Equipment Supplied with Home Laboratory Experiment No. 7A

The parts and equipment supplied with Home Laboratory Experiment No. 7A are illustrated and listed in Figure 1.

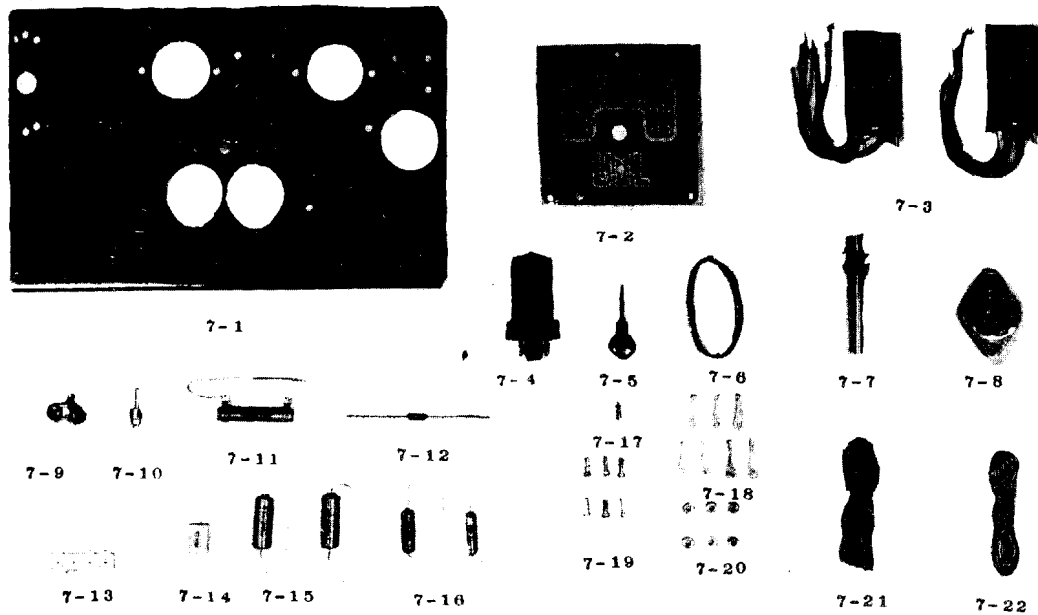

PARTS SUPPLIED WITH HOME LABORATORY EXPERIMENT NO.7A

PART NO.	DESCRIPTION
7-1	Chassis
7-2	Dial
7-3	2 1-F transformers
7-4	6SA7 tube
7-5	Dial pointer
7-6	Length of dial cord
7-7	Dial panel bearing
7-8	Octal tube socket
7-9	Phono input jack
7-10	Phono input plug
7-11	3000 ohm 10 watt filter resistor
7-12	10 megohm resistor
7-13	3 lug terminal strip
7-14	50 mmfd. mica capacitor
7-15	2-.02 mfd. capacitors
7-16	2-.005 mfd. capacitors
7-17	Dial spring
7-18	7 soldering lugs
7-19	6-6/32 screws
7-20	6-6/32 nuts
7-21	Hookup wire
7-22	Solder

FIGURE 1

Instructions for Each Part of the Experiment

This Home Laboratory Experiment is divided into several Parts. Each of these Parts constitutes a separate experiment in itself and should be performed as such. These experiments should be performed carefully and completely. Take your time and do not rush through the experiment. Be sure to perform the experiment with the viewpoint in mind of obtaining the maximum amount of information

If you are to obtain maximum information from this Home Laboratory Experiment you will have to spend several hours on it. It is advisable that you schedule your time so that you will have several evenings free for this purpose. Do not lose sight of the fact that the object of performing the experiment is to learn. The experiments provide the opportunity to gain the necessary practical knowledge, but you yourself must do the learning. The only way to achieve this end is to perform the experiment carefully and completely, using the following general suggestions.

1. Before connecting the circuit in each Part of the experiment, read that Part carefully. Analyze, in your mind, the way in which the circuit should operate. This is very important. Get into the habit of thinking about the manner in which circuits operate.
2. Be sure to perform the steps in each Part of the experiment in the order given. Record your results in the spaces provided.
3. Read the discussion carefully and analyze your results.
4. Answer the Test Question on each Part of the experiment at the end of the text before proceeding with the next Part.

General Procedure

A complete superheterodyne receiver will be constructed in this experiment. The circuit will be wired a section at a time, and each section will be checked before proceeding with the remainder of the circuit. For example, first the power supply is wired and the various output voltages are measured. Then the audio power amplifier will be wired and checked, followed by the audio voltage amplifier, the second detector, the i-f stage and the converter. By following this system it should be very easy to locate any incorrect connection.

A schematic diagram will be given for each circuit and a pictorial diagram will be included to illustrate the manner in which the various parts should be located. The pictorial diagram

should be checked to determine the proper placement of the main components, but the circuit should be wired following the schematic diagram. This system is employed to provide you with the opportunity to wire circuits directly from the schematic diagram. The importance of being able to do this cannot be over emphasized. After a circuit has been wired, it should be checked carefully against the schematic diagram. After this, the circuit should be checked against the pictorial diagram as a safety factor. You should make every attempt to wire the circuits as much as possible without the aid of the pictorial diagrams.

The reason that wiring the circuits from the schematic diagrams has been stressed is due to the fact that, in very few instances are pictorial diagrams available, or for that matter, used, if available. For example, an electronics technician building equipment in a laboratory rarely has a pictorial diagram to work from; a radio or television serviceman works almost exclusively with a schematic diagram, etc. For this reason you should strive to become efficient in the use of schematic diagrams.

The Complete Circuit

The complete schematic of the superheterodyne receiver to be constructed in this experiment is shown in Figure 2.

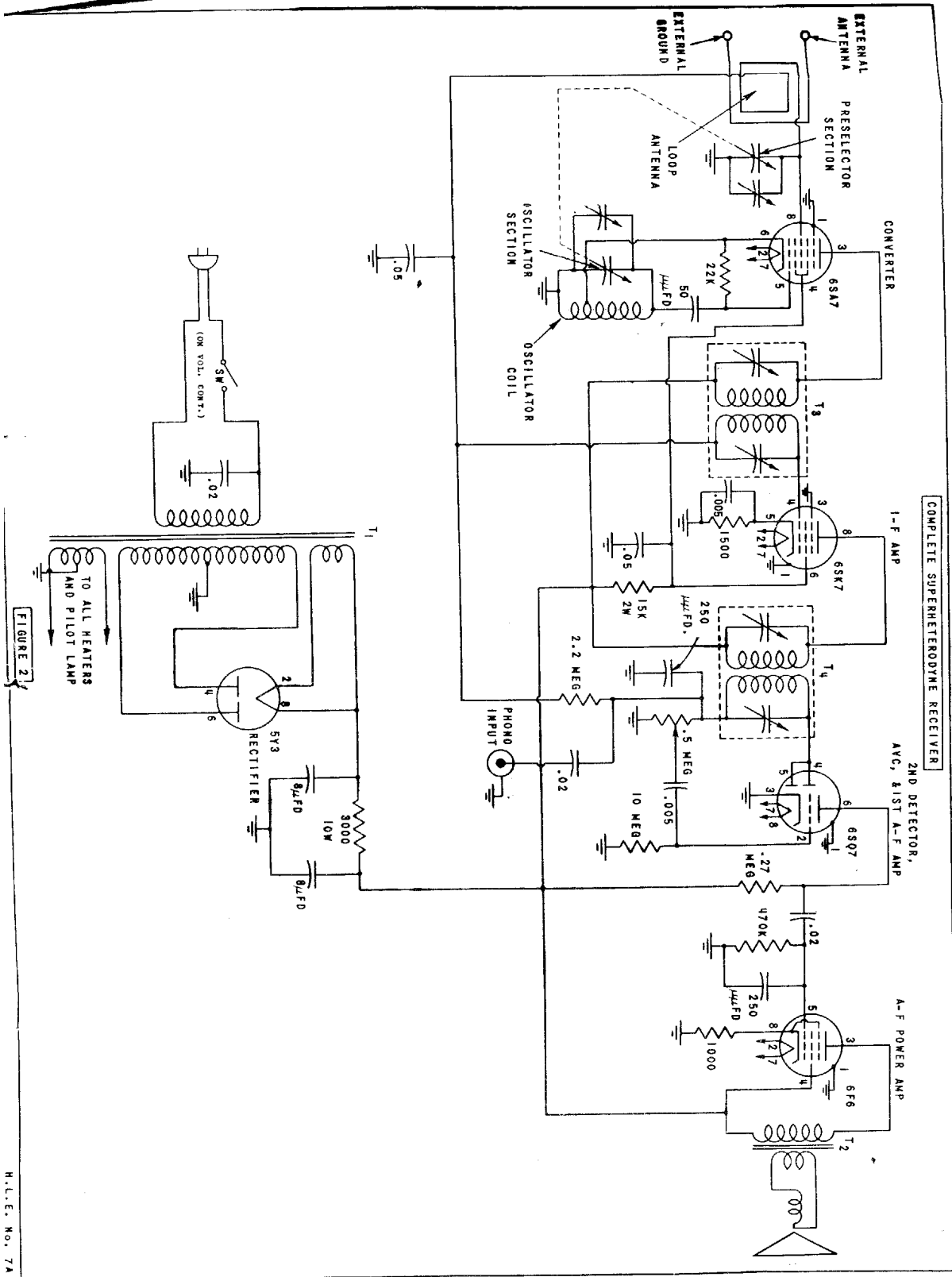

FIGURE 2

H. L. E. No. 7A

Before proceeding with the experiment, analyze this circuit very carefully referring to the appropriate assignment material if necessary, to make sure that you understand the operation of each circuit and the purpose of each component in the circuit.

The superheterodyne receiver employs

- 6SA7 converter stage,
- 6SK7 i-f amplifier,
- 6SQ7 second detector, AVC, and first a-f amplifier,
- 6F6 power amplifier, and
- 5Y3 rectifier tube.

The power supply circuit employs full-wave rectification and a condenser-input filter.

The selectivity and sensitivity of this receiver compares favorably with that of the great majority of commercially available broadcast superheterodyne receivers.

Automatic volume control is included and should maintain a relatively constant output signal under fading conditions and prevent blasting when tuning from one station to another.

Current type inverse feedback is used in the power amplifier stage to improve the fidelity of the reproduced signal.

The phono input jack is coupled to the first audio-frequency amplifier in such a manner that the receiver volume control also serves as the volume control for the phono amplifier.

PART 1

Mounting the Parts and Stringing the Dial

Figure 3 shows a bottom view of the superheterodyne receiver chassis. The mounting holes for the various components are labeled in this figure. When mounting the parts, if any question arises concerning the proper location, refer to Figure 3.

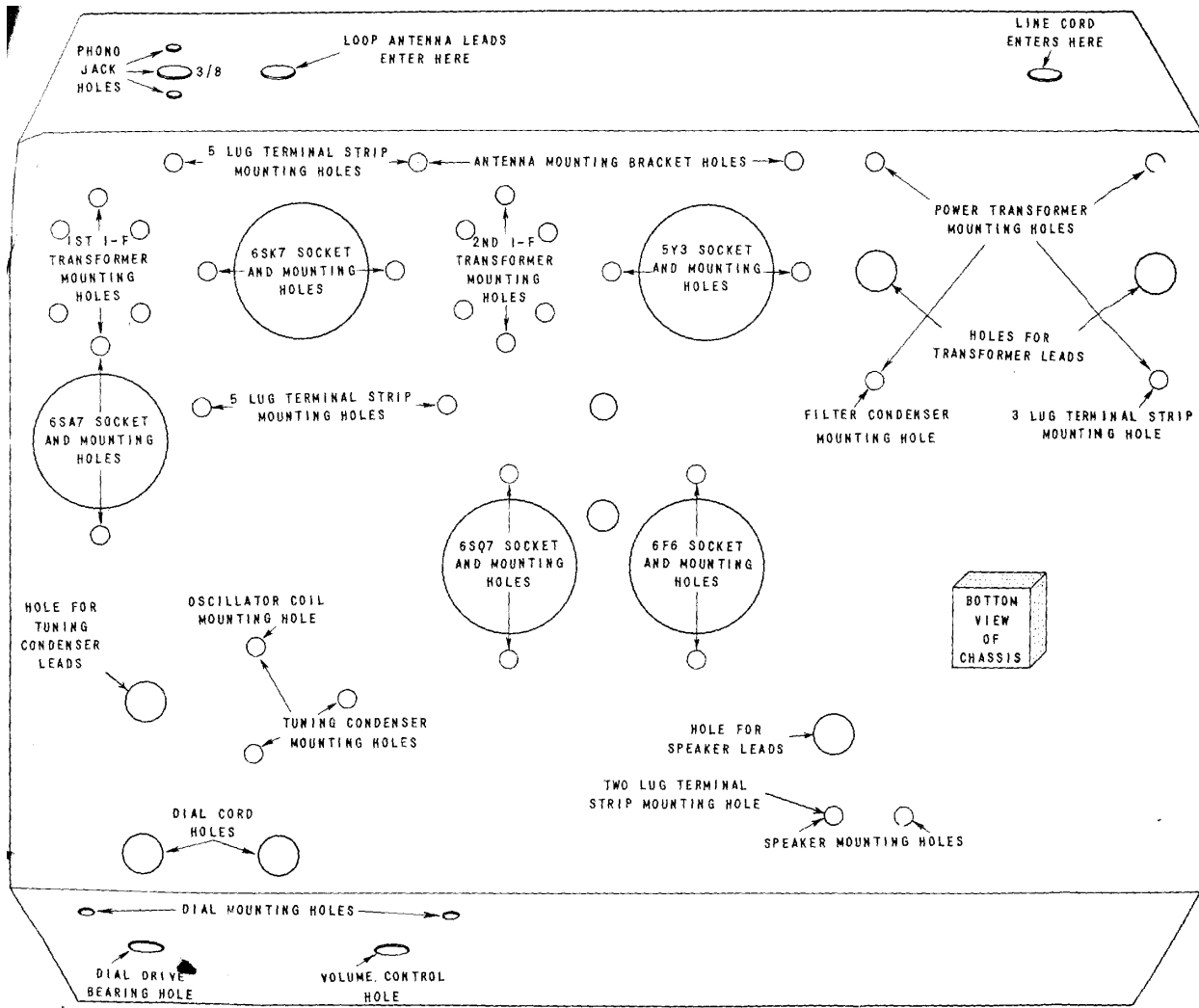

Step 1. Mounting the I-F Transformers

Mount the two i-f transformers as illustrated in Figure 4.

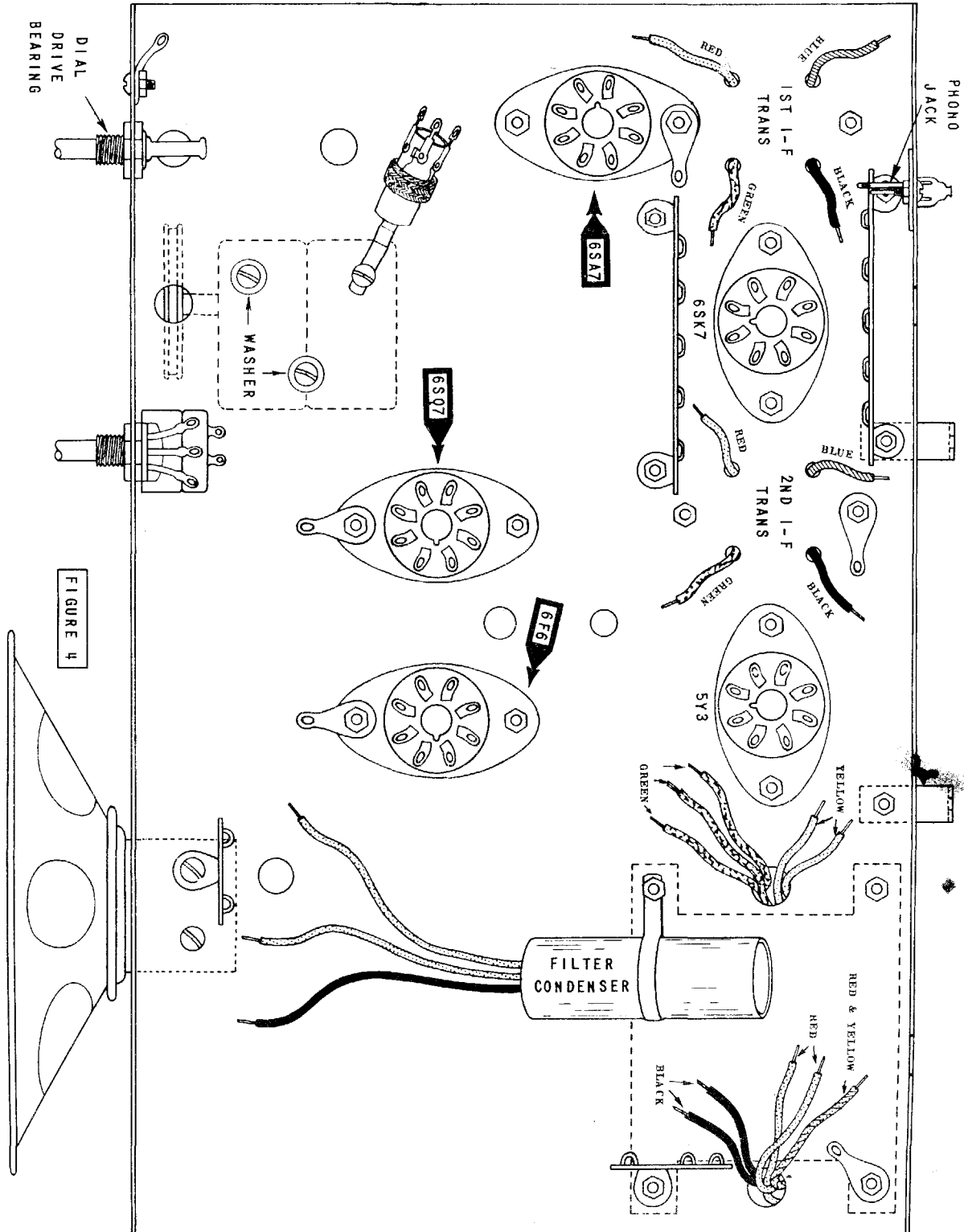

FIGURE 4

Be sure that the colored leads pass through the proper holes as illustrated. Do not twist the leads together in the shield can; instead, bring them straight down through the holes as

indicated in Figure 4. Note that a soldering lug should be placed on one of the mounting screws before tightening the nut and that one of the mounting screws is also used for mounting one side of the 6SA7 tube socket.

Step 2. Mounting the Tube Sockets

Mount the five tube sockets on the chassis as illustrated in Figure 4. Be sure that each key is pointed in the direction indicated. Mount the soldering lugs on the tube sockets as illustrated.

Step 3. Mounting the Power Transformer

- Mount the power transformer as illustrated in Figure 4.
- A soldering lug should be mounted on one of the power transformer mounting screws,
- a three-lug terminal strip on another and
- the filter capacitor on the third mounting screw as illustrated.
- Be sure and mount the transformer with the proper leads projecting through the holes as illustrated.

Step 4. Mounting the Tuning Condenser

- Mount the tuning condenser using three screws and two washers as illustrated.
- The oscillator coil is mounted by means of the third mounting screw for this condenser.
- Mount the dial drive bearing and the potentiometer in the holes as illustrated in Figure 4.

Step 5. Mounting the Loudspeaker

- Mount the loudspeaker with the two 8/32 machine screws as illustrated.
- Also mount the two-lug terminal strip under one of these mounting screws.

Step 6. Mounting the Five-Lug Terminal Strips

- Mount the two five-lug terminal strips as illustrated in Figure 4.
- Also mount the antenna mounting brackets at this time.
- However it is advisable not to mount the loop antenna as yet.
- Note that one end of one of the terminal strips and one of the antenna brackets are fastened with the same machine screw.

- Mount the phono jack as illustrated in Figure 4. Be sure that the circular bakelite portion of this jack is on the inside of the chassis.

Step 7. Stringing the Dial Mechanism

In the great majority of broadcast receivers, the tuning is accomplished through an arrangement whereby a large drum on the condenser shaft is coupled to a small dial drive bearing by means of a dial cord. This arrangement permits a degree of "vernier" tuning which is not obtainable if the tuning knob is mounted directly on the condenser shaft. The dial cord is subjected to wear during repeated use and will eventually break. For this reason a radio serviceman is often called upon to replace a dial cord. In "stringing" this dial, the Associate will obtain experience in this operation. The arrangement used in this superheterodyne receiver is often employed in small table model receivers. However, in more elaborate receivers, particularly those employing slide rule dials, the manner in which the dial cord is arranged to secure the desired results is rather complex, sometimes requiring reference to a service manual to successfully complete the job.

To string the dial cord on the receiver, proceed as illustrated in Figure 5.

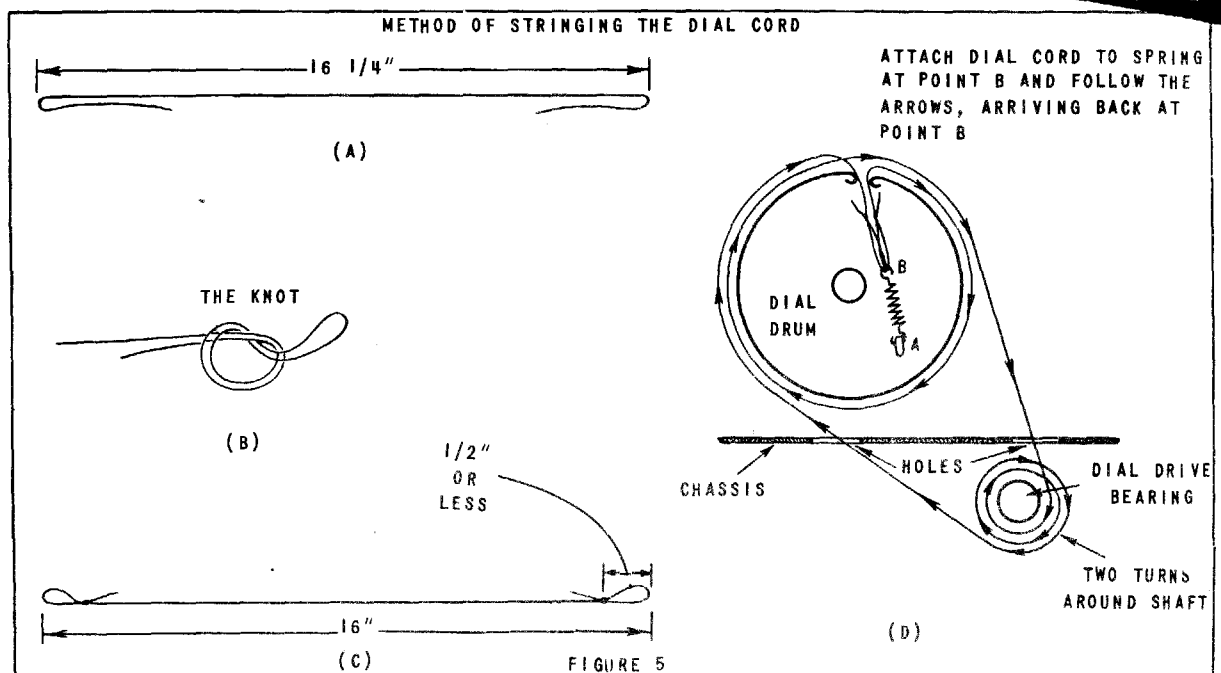

- Loop back the ends of the length of dial cord Part No. 7-6 supplied with this Home Laboratory Experiment as illustrated in Figure 5(A).
- A loop will have to be tied in each end of the cord to form an arrangement as illustrated in Figure 5(C). To do this, tie the knot illustrated in Figure 5(B) on each end of the length of dial cord. Notice particularly that upon completion the over-all length of the cord should be 16.25 inches. The loops on the ends of the cord should be as small as possible, and never greater than one half inch in length.
- After you have your length of cord tied, measure it to make sure that it is the proper length. If the length is not correct untie the knots and repeat.
- After the cord has been made the proper length, the dial should be strung as illustrated in Figure 5(D).
- To perform this operation, rotate the shaft of the tuning condenser to the *maximum counterclockwise* position. This will cause the plates of the condenser to be *completely meshed*. Place one end of the dial spring Part No. 7-17 on the projection on the dial drum labeled A in Figure 5(D).
- Place the loop on one end of the dial cord over the other end of the spring and pass the cord through the indentation in the edge of the dial drum. Pass the cord one complete revolution around the drum wheel and then pass it through the hole in the chassis below this edge of the drum wheel.
- Now pass the dial cord two complete revolutions around the dial drive bearing.
- Note: Actually this will make approximately two and one half turns around this bearing.
- Now pass the end of the dial cord through the other dial cord hole in the chassis and up over the left edge of the dial drum. Pass the end of the cord through the indentation in the edge of the drum and hook it on the spring at point B.
- If your cord is the correct length and you have followed the instructions provided and illustrated in Figure 5(D), your cord should be held securely.
- Mount one of the knobs on the end of the dial bearing and the other knob on the potentiometer shaft; check to see that your dial works properly.

Step 8. Mounting the Dial and Dial Pointer

Mount the dial, Part No. 7-2 with two 6/32 screws as shown in Figure 6(A).

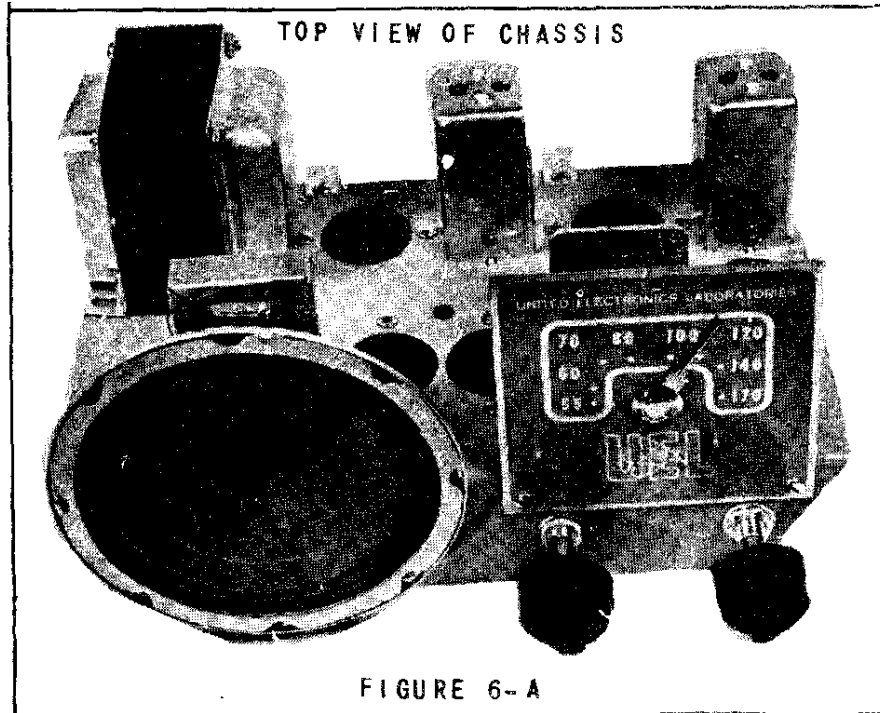

Place a soldering lug on the back of one of these screws as illustrated in Figure 4. Make sure that the tuning condenser is rotated to its maximum counterclockwise position (plates fully meshed) and place the dial pointer on the end of the condenser shaft so that it is lined up directly with the dot alongside number 55. This indicates 550 KHz on the dial.

Now rotate your tuning knob to make sure that your dial pointer moves across the scale to approximately 170 indicating that the condenser is opening to its maximum clockwise position.

Upon completion of this Part of the experiment the top of your chassis should appear as illustrated in Figure 6(A) and the bottom should appear as illustrated in Figure 6(B).

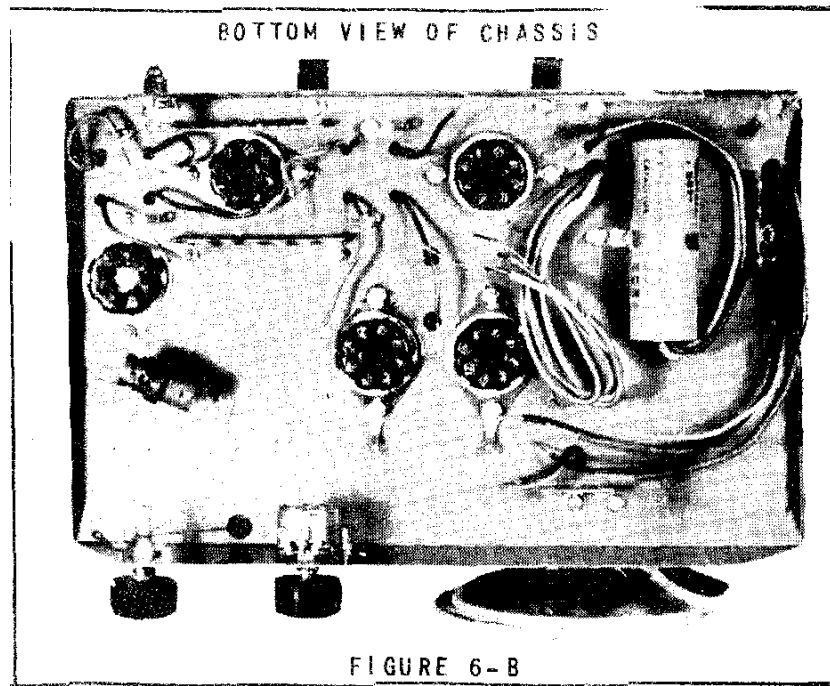

Discussion

Since there was very little technical information included in this Part of the experiment little or no discussion is necessary. This Part of the experiment of course provided for the correct mounting of the major components of the superheterodyne receiver and also gave detailed instructions on stringing the dial.

Answer Test Question Number 1 at the end of the experiment.

PART II

The Power Supply and Heater Circuits

In wiring the power supply and all of the other circuits in this receiver, you should cut off the ends of the various leads so that direct, short connections can be obtained.

Step 1. Examining the Circuit

Figure 7 shows the schematic diagram of the power supply that will be used in the superheterodyne receiver.

Lab 7A Superhet Radio

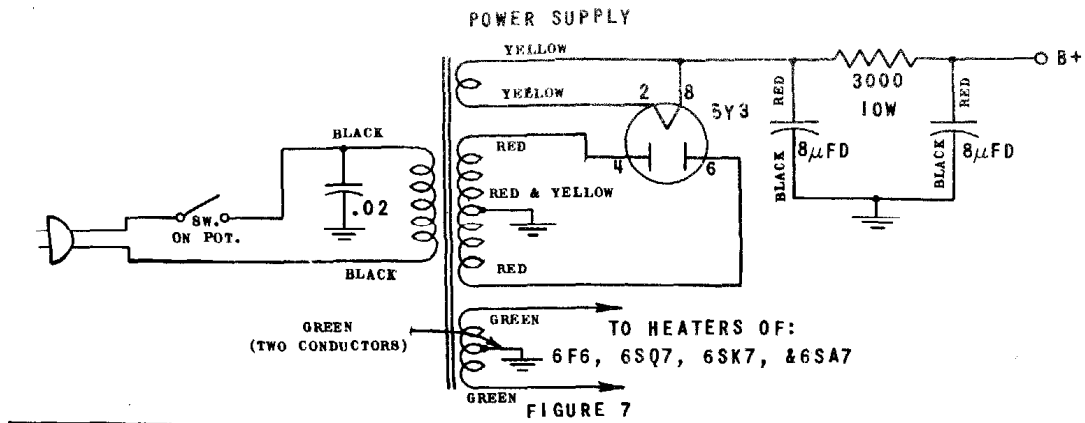

It will be noted that this supply employs a full-wave rectifier and a pi-type filter composed of two 8-mfd condensers and a 3000 ohm, 10 watt, filter resistor.

The on-off switch on the potentiometer is connected in series with the primary of the power transformer as is customary in radio circuits.

A 0.02-mfd capacitor is connected from one side of the primary to ground as a hash filter. This capacitor bypasses noise that may enter the receiver through the line cord. If, during the operation of your receiver, you find a rather high degree of background noise this may be because the hash filter is connected between the grounded a-c line and the chassis, and is, therefore ineffective. In this case you will probably find that reversing the a-c plug will minimize this noise.

Step 2. Wiring the Power Supply and Heater Circuits.

Figure 8 shows a pictorial diagram of the manner in which the parts should be placed for the power supply and heater circuits.

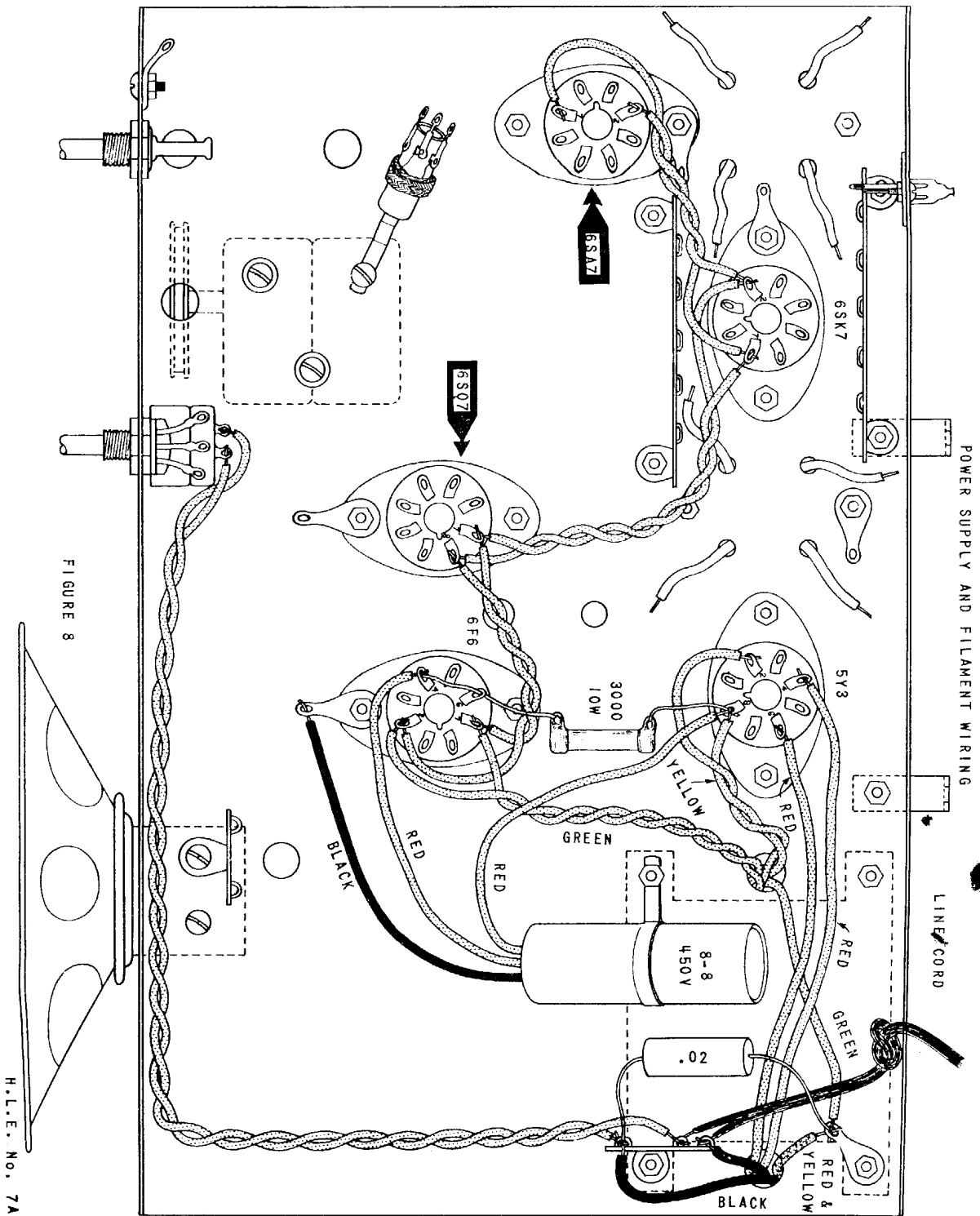

Notice that the number 6 and number 4 pins of the 6F6 tube socket are used as the B+ terminals of the power supply. If Figure 2 is examined the reason for this can be seen. In the schematic diagram the B+ ties directly to the number 4 pin of

Lab 7A Superhet Radio

the 6F6 tube which is the screen grid. Pin number 6 of this tube is unused and forms a convenient tie point. This is another fact that should be emphasized. It is customary in commercial equipment to use the unused terminals of various tube sockets as tie points for resistors, capacitors, etc.

The following chart gives the color code for the power transformer, for your convenience in wiring this circuit.

Primary leads	Black
H. V. Secondary leads	Red
Center tap of H. V. Secondary	Red and Yellow
5V Fil. Winding (5Y3)	Yellow
6.3V Fil. Winding	Green
Center Tap of 6.3V winding	Green and Yellow (Two Green Conductors in some cases)

Hook up your power supply and heater circuits, following the schematic diagram of Figure 7, and the following suggestions.

- Before connecting the line cord to the soldering-lug terminals provided, tie a knot in the cord inside the chassis as illustrated so that if the cord is pulled, pressure will not be applied to the solder connections.
- In wiring this section of the circuit the heaters should be wired first. Be sure to twist these leads together and route the leads close to the chassis so that minimum hum will be induced into other circuit components.
- When connecting the center tap of the 6.3 volt a-c winding to the grounding soldering lug make sure that the insulation is scraped from both conductors in this lead and that both conductors are securely soldered to the grounding soldering lug.

In the wiring arrangement shown in Figure 8 note the manner in which the a-c leads, the switch, and the primary of the power transformer are connected.

Notice that one lead from the line cord connects directly to one end of the primary winding. The other a-c lead connects to a terminal on the terminal strip and one lead of a pair of twisted leads runs from this terminal to one of the switch terminals on the potentiometer. The other lead of the twisted pair of leads runs from the other switch terminal to the third terminal of the soldering-lug terminal strip. The other primary lead also connects at this point. If this circuit is traced it will be found that the arrangement is such that the switch is connected

in series between the primary winding and one of the 110 volt AC lines. The 0.02 mfd capacitor connected between the ground soldering lug and one end of the primary winding is the hash filter mentioned previously.

After completing the wiring of the circuit as indicated by the schematic diagram of Figure 7, carefully check your circuit. Now double check your wiring against the pictorial diagram of Figure 8.

Step 3. Point-to-Point Resistance Measurements

Table 1 provides spaces for recording your point-to-point resistance measurements made from the chassis ground to the tube socket pins of the 5Y3 and the 6F6 tube sockets.

TABLE 1

POINT-TO-POINT RESISTANCE MEASUREMENTS CHASSIS GROUND TO FOLLOWING POINTS:									
PIN NO.		1	2	3	4	5	6	7	8
5Y3	YOUR READING				4		3		2
	UEL READING	∞	500K	∞	195*	∞	210*	∞	500K
6F6	YOUR READING								
	UEL READING	∞	0	∞	500K	∞	500K	0	∞

* READING FOR PINS 4 AND 6 MAY BE REVERSED
DEPENDING ON TRANSFORMER CONNECTIONS.

These readings should be made before the rectifier tube is inserted and before the a-c plug is connected to the power source. In making these readings the method employed should be the same as that employed when making resistance measurements in any other case. First the high range of the ohmmeter should be used. If a satisfactory reading is obtained on the high-ohm scale that value should be recorded.

If however a zero, or near zero reading is obtained the meter should be converted to a low-range ohmmeter and an accurate reading made.

- In making these measurements one other effect can be noted and that is the fact that the high resistance readings will be different if different leads of the

multimeter are connected to chassis. For example, the UEL reading of 500,000 ohms indicated for pin number 2 of the 5Y3 tube socket was obtained with the red test lead grounded and the black test lead connected to the tube socket pin.

- However, if the two test leads are reversed a lower reading of approximately 100,000 ohms is obtained. This change in resistance due to reversing of the test leads results from the change of polarity of the voltage from the multimeter battery as it is applied to the filter capacitor.
- When the test leads are so arranged that negative voltage is connected to the B+, the resistance measurement obtained is lower than if a positive voltage is applied at this point.

Your resistance readings should correspond closely to those taken at UEL on a similar circuit and listed in Table 1.

Step 4. Point-to-Point Voltage Measurements

If your resistance measurements correspond closely to those taken at UEL as listed in Table 1, insert the 5Y3 tube in its socket, connect the line cord to the a-c receptacle and turn on the switch on the potentiometer. Observe the 5Y3 tube when you do this. The filaments in the tube should heat up in a few seconds and no other change in the tube should be noted. This precaution is stressed, since, if a short circuit exists in your wiring, the plates on the 5Y3 tube may become red very quickly. If this occurs, the circuit should be de-energized very quickly, and the trouble located.

If the plates of the 5Y3 tube do not become red make the point-to-point voltage measurements to fill in the spaces provided in Table 2.

To do this, use your multimeter as a 750 volt d-c meter and make the measurements with the black test lead connected to the chassis and the red test lead contacting the tube socket pins indicated. Record your readings in the spaces provided in Table 2.

TABLE 2

POINT-TO-POINT VOLTAGE MEASUREMENTS CHASSIS GROUND TO FOLLOWING POINTS:									
PIN NO.		1	2	3	4	5	6	7	8
5Y3	YOUR READING				OMIT		OMIT		
	UEL READING	0	475V	0		0		0	475V
6F6	YOUR READING		OMIT					OMIT	
	UEL READING	0		0	470V	0	470V		0

Now convert your meter to a 0 to 15 volt a-c meter by placing the AC-DC switch in the AC position and the rotary selector switch in the 15 volt AC position. Measure heater voltage of the various tubes as indicated in Table 3 and record your voltage readings.

TABLE 3

POINT-TO-POINT VOLTAGE MEASUREMENTS BETWEEN THE FOLLOWING POINTS:				
	PINS 2 & 7 OF 6F6	PINS 7 & 8 OF 6S07	PINS 2 & 7 OF 6SK7	PINS 2 & 7 OF 6SA7
YOUR READING				
UEL READING	6.3V	6.3V	6.3V	6.3V

If your voltage readings correspond closely to those obtained on the circuit at UEL as indicated in Table 2 and Table 3, your power supply has been wired properly.

Discussion

The power supply constructed in this Part of the experiment furnishes the plate supply voltage and the heater voltage for all tubes in the super heterodyne circuit. This power supply employs a full-wave rectifier tube, 5Y3, and a pi-type filter.

The operation of this circuit is very similar to the operation of the full-wave rectifier with pi-type filter constructed in Home Laboratory Experiment No. 3; the only difference being the fact that a 3000-ohm, 10 watt filter resistor is used in place of the filter choke. The output voltage obtained from this circuit (without load) should be practically the same value as you have recorded for your full-wave rectifier with pi-type filter in Home Laboratory Experiment No. 3.

Answer Test Question Number 2 at the end of the experiment.

PART III

The Power Amplifier Circuit

The power amplifier circuit is the circuit that builds up the relatively weak power output from the first audio amplifier to a value sufficiently large for operation of the loudspeaker.

Step 1. Analyzing the Circuit.

The schematic diagram of the power amplifier stage is shown in Figure 9.

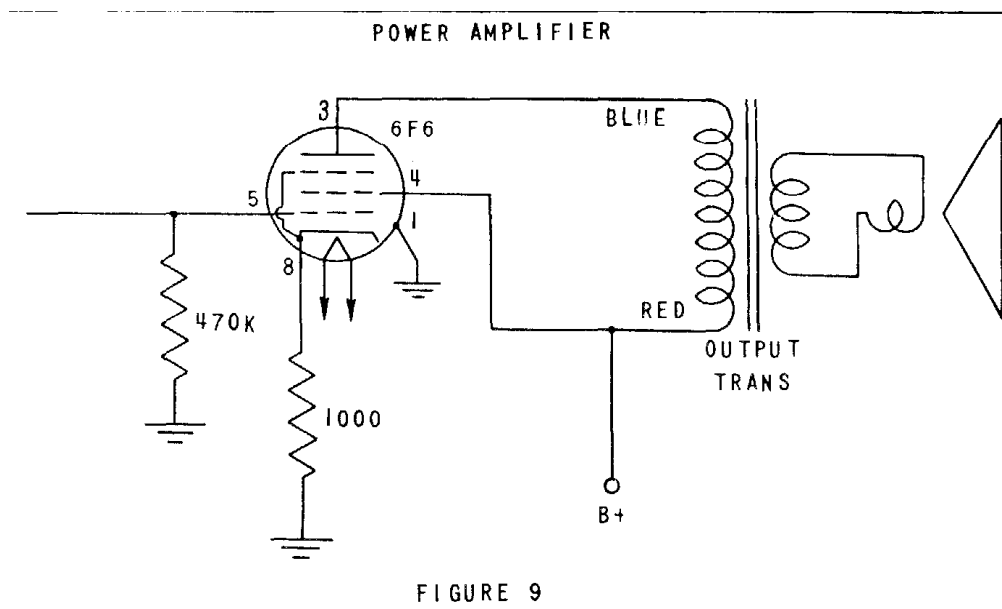

- A 6F6 tube is used and the output signal from it is coupled through the output transformer to the permanent magnet type of dynamic loudspeaker.

- A 1000-ohm resistor in the cathode circuit provides the operating bias for the stage, and since it is un-bypassed, also produces current type, inverse feedback to increase the fidelity of the amplifier.
- The screen grid of this tube is operated directly from the B+ that is a characteristic of the power amplifier type of pentode tube.
- A 470,000-ohm resistor connected between grid and ground forms the grid load resistance.

Step 2. Wiring the Circuit

The pictorial diagram of the wiring of the 6F6 power output stage is illustrated in Figure 10.

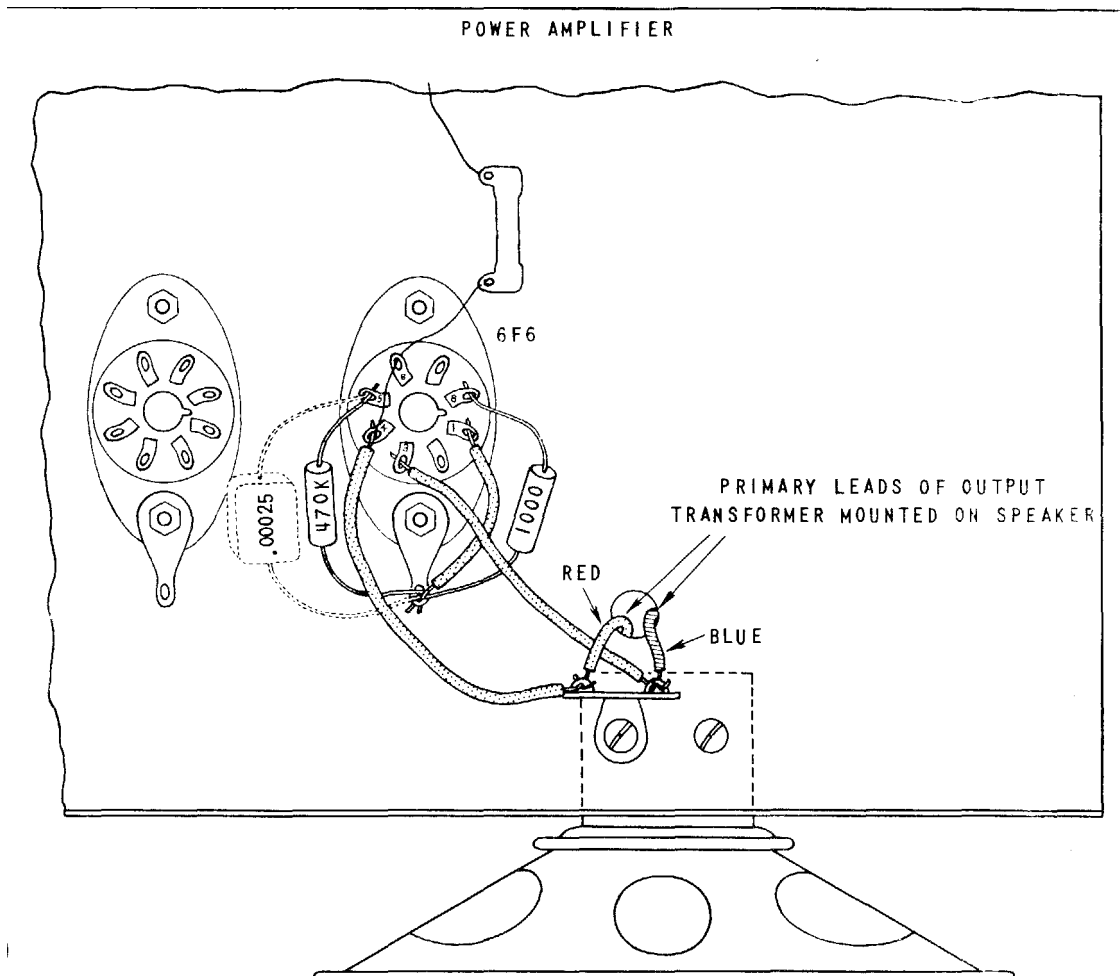

It will be noted that the heater circuits are not shown, and in addition, the majority of the power supply circuit shown in Figure 8 is not redrawn. Only those components directly affected

Lab 7A Superhet Radio

by this section of wiring are shown. This same general method will be employed in the pictorial diagrams.

If the schematic diagram of Figure 2 is examined it will be seen that a 0.00025 mfd capacitor is shown connected between the grid of the 6F6 tube and ground; however, this capacitor is not shown in Figure 9. This component is a high-frequency bypass capacitor that is used to improve the tone quality of the outputs signal; however, it should not be wired in the circuit at present. The capacitor will be used later in this experiment during the alignment of the receiver. After the alignment has been completed it should be connected in the circuit as indicated by the dotted 0.00025 mfd capacitor between pin number 5 of the 6F6 tube socket and ground in Figure 10.

In order that the wiring of your receiver will have as professional an appearance as possible, a photograph of the underside of this completely wired superheterodyne receiver is shown in Figure 11.

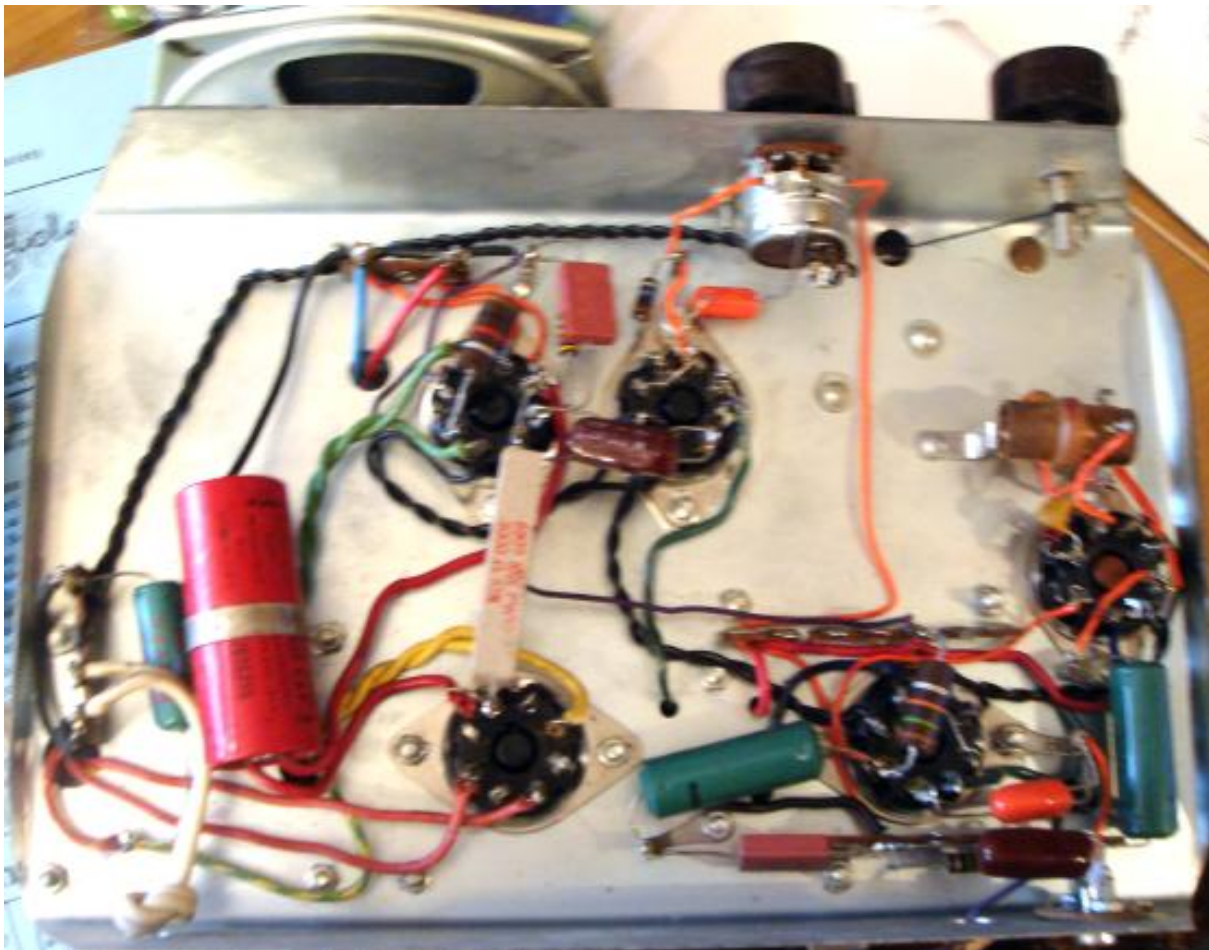

In this photograph the arrangement of the various parts can be seen. This photograph should be used to supplement the various partial pictorial diagrams to enable you to correctly place your parts.

Wire the power amplifier stage of your receiver following the schematic diagram of Figure 9 and the pictorial diagram of Figure 10. After you have completed wiring this section of the receiver check your wiring carefully against the schematic diagram, then check it against the pictorial diagram.

Step 3. Point-to-Point Resistance Measurements

Before inserting the 6F6 tube in its socket and applying the plate voltage, a point-to-point resistance check should be made. Table 4 provides spaces for recording the point-to-point resistance values which you measure.

TABLE 4

POINT-TO-POINT RESISTANCE MEASUREMENTS CHASSIS GROUND TO FOLLOWING POINTS:									
PIN NO.		1	2	3	4	5'	6	7	8
6F6	YOUR READING								
	UEL READING	0	0	500K	500K	470K	500K	0	1000

Step 4. Point-to-Point Voltage Measurements

Before inserting the 6F6 tube in the socket make the point-to-point voltage measurements to fill the blanks in the first part of Table 5.

TABLE 5

POINT-TO-POINT VOLTAGE MEASUREMENTS CHASSIS GROUND TO FOLLOWING POINTS:										
PIN NO.		1	2	3	4	5	6	7	8	
6F6 SOCKET <u>WITHOUT</u> TUBE	YOUR READING		OMIT					OMIT		
	UEL READING	0		470	470	0	470		0	
6F6 SOCKET <u>WITH</u> TUBE	YOUR READING									
	UEL READING	0		320	325	0	325		28	

If your readings check closely with those obtained at UEL, insert the 6F6 tube in the socket and make the point-to-point voltage measurements to fill the blanks in the lower part of this table.

1. Is your B+ supply voltage lower with the 6F6 tube inserted than without the 6F6 tube?
2. Why?

Step 5. Checking the Power Amplifier

Your power amplifier may be checked very easily. To do this it is only necessary to touch your finger to the blade of your screwdriver and touch the tip of this blade to the grid (pin number 5) of the 6F6 tube. A low hum should be heard in the loudspeaker.

Discussion

The wiring of the power amplifier stage of the superheterodyne receiver is relatively simple and little difficulty should be encountered.

A power amplifier stage such as the 6F6 stage in this receiver is for the purpose of developing sufficient power for operation of the loudspeaker. To accomplish these results, a relatively large input signal is required. This is the reason that only a weak signal is heard when the grid is touched. The stray signal which is injected under these conditions is very small, consequently very little output is obtained. When a strong input signal is applied to this stage from the audio voltage amplifier a strong output signal will be obtained.

Answer Test Question Number 3 at the end of the experiment.

PART IV

The Audio Voltage Amplifier

In a radio receiver, the output signal from the second detector represents a voltage variation whose amplitude is quite small. An audio voltage amplifier is used to amplify the signal to a sufficiently large value for application to the grid circuit of the power amplifier. In this Part of the experiment the audio voltage amplifier will be constructed.

Step 1. Analyzing the Circuit

Figure 12 shows the schematic diagram of the audio voltage amplifier circuit that will be used in this superheterodyne receiver.

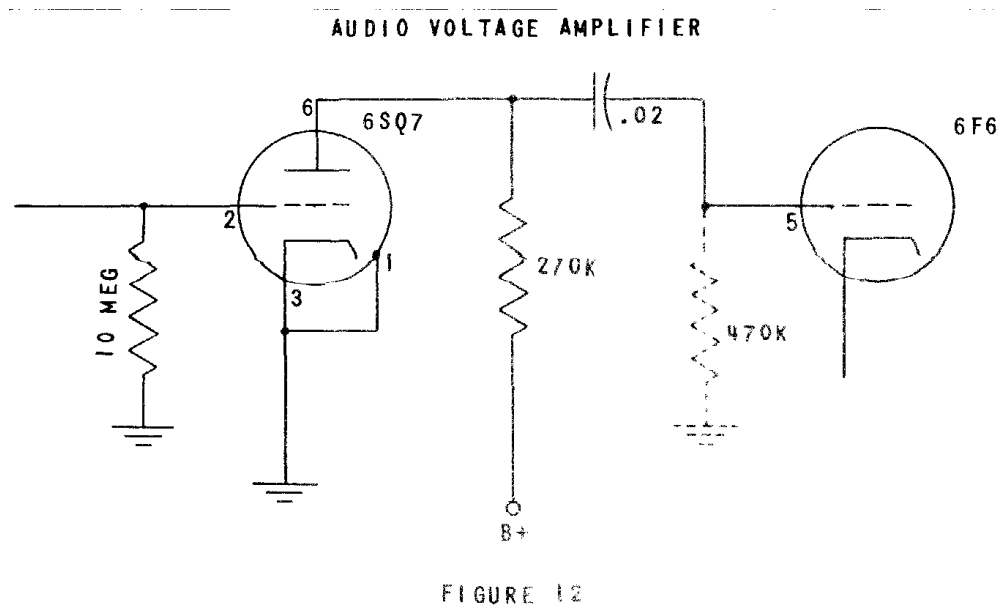

The triode section of the 6SQ7 tube is used for this operation. A 270,000-ohm plate load resistor is employed and the audio signal is coupled through a 0.02-mfd capacitor to the grid circuit of the 6F6 stage. The 10-megohm resistor connected between the grid of the 6SQ7 tube and ground acts as the grid load resistor and also provides the operating bias for the stage.

A few of the electrons leaving the cathode strike the grid and as they flow through the 10-megohm resistor develop a d-c voltage across the resistor.

The end of the resistor connected to the grid is negative.

The grounded end, connected electrically to the cathode, is positive.

In this manner bias is provided for the tube. It should be emphasized that this type of bias is not grid-leak bias in the normal sense of the word. To obtain grid leak bias the grid is driven positive by the *input* signal and the current that flows develops the bias voltage.

However, in this type of an arrangement a very large grid load resistor is used and the bias is developed by the electrons that strike the grid as they pass from the cathode toward the plate. This current is very small, but since a large resistor is used, a satisfactory amount of bias voltage is developed.

Step 2. Wiring the Circuit

The audio voltage amplifier stage should now be wired following the schematic diagram of Figure 12.

Figure 13 shows the parts layout for this stage.

AUDIO VOLTAGE AMPLIFIER

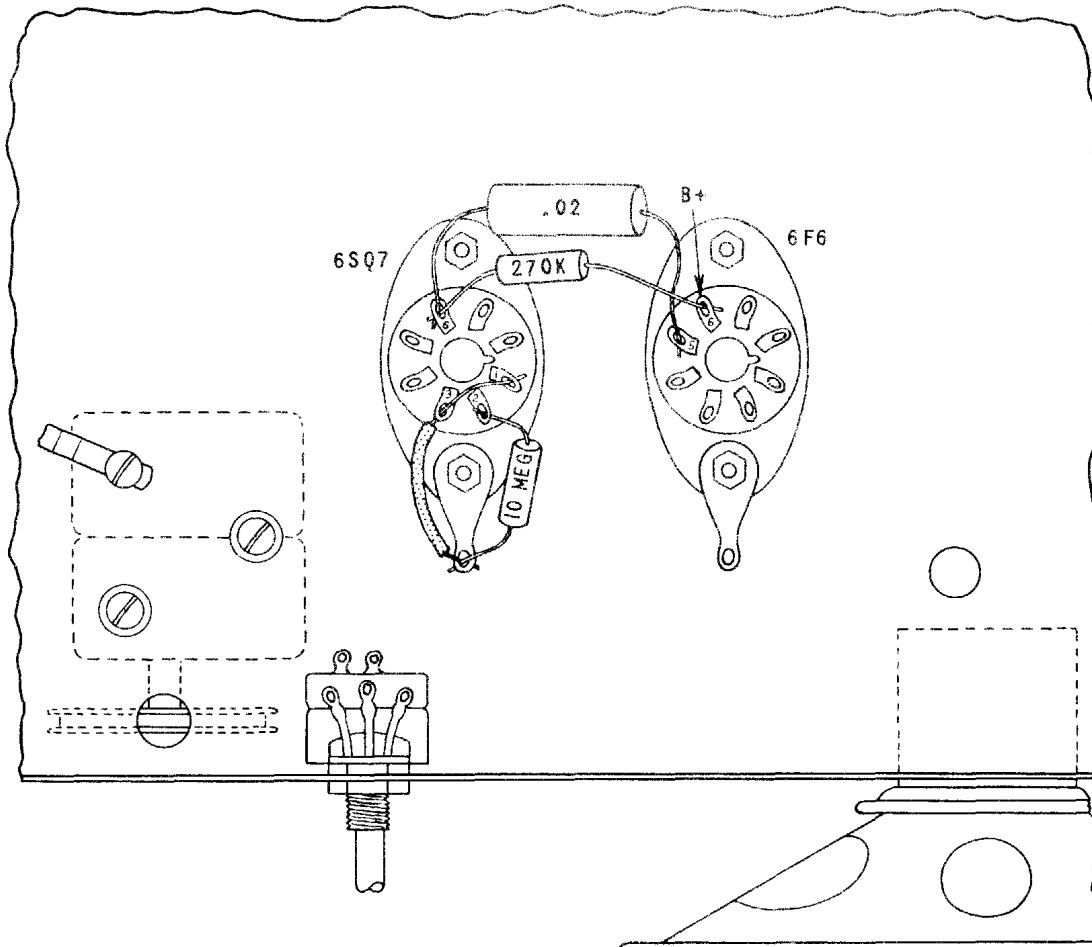

FIGURE 13

After you have completed your wiring, check it carefully against the schematic diagram and the pictorial diagram.

Step 3. Point-to-Point Resistance Measurements

Make the point-to-point resistance measurements necessary to fill the blanks in Table 6.

TABLE 6

POINT-TO-POINT RESISTANCE MEASUREMENTS CHASSIS GROUND TO FOLLOWING POINTS:									
PIN NO.		1	2	3	4	5	6	7	8
6S07	YOUR READING								
	UEL READING	0	∞	0	∞	∞	300K	0	0

Step 4. Point-to-Point Voltage Measurements

Before inserting the 6SQ7 tube in its socket, point-to-point voltage measurements should be made. Record your readings in the spaces provided in the top portion of Table 7.

TABLE 7

POINT-TO-POINT VOLTAGE MEASUREMENTS CHASSIS GROUND TO FOLLOWING POINTS:									
PIN NO.		1	2	3	4	5	6	7	8
6SQ7 SOCKET <u>WITHOUT</u> TUBE	YOUR READING							OMIT	OMIT
	UEL READING	0	0	0	0	0	225V		
6SQ7 SOCKET <u>WITH</u> TUBE	YOUR READING								
	UEL READING	0	0	0	0	0	100V		

If your voltage readings check closely with the UEL readings as indicated in Table 7, insert the 6SQ7 tube in the socket and make the necessary measurements to fill in the blanks in the lower part of Table 7.

Step 5. Checking the Amplifier

The two-stage audio amplifier that you now have constructed is a high-gain audio amplifier. To check this amplifier touch your finger to the blade of your screwdriver and touch the tip of the blade to the grid of the 6SQ7 tube (pin number 2). A loud hum should be heard in the output. If you desire to further check this audio amplifier you may couple an audio signal to this grid from another source as in preceding Home Laboratory Experiments.

Discussion

The audio-frequency amplifier which has now been constructed is a two-stage high-gain audio amplifier. This amplifier is typical of the audio amplifiers to be found in radio receivers. The Associate should by now be quite familiar with the operation of this type of amplifier since a number of very similar amplifiers have been constructed previously.

Answer Test Question Number 4 at the end of the experiment.

PART V

The Second Detector

The second detector stage in the superheterodyne receiver converts the amplitude-modulated i-f signal to an audio signal. As in practically all modern superheterodyne receivers, a diode detector is employed.

Step 1. Analyzing the Circuit

Figure 14 shows the schematic diagram of the diode detector circuit used in this superheterodyne receiver.

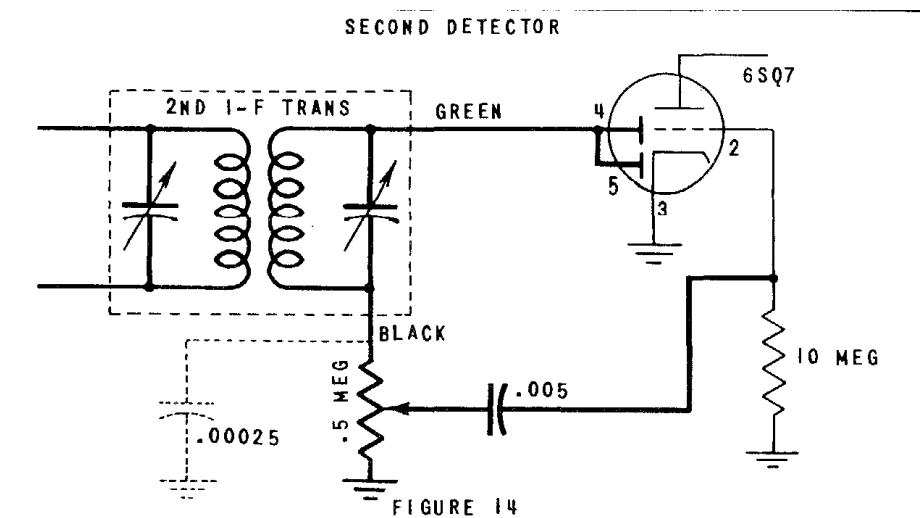

It can be seen that this circuit is a simple series-type diode detector circuit. The r-f signal that is developed across the tuned secondary winding of the i-f transformer is applied between the cathode and diode plates of the 6SQ7 tube. This circuit acts as a half-wave rectifier, developing a pulsating DC voltage across the 0.5 megohm potentiometer.

In the completed receiver a 0.00025 mfd capacitor is connected across the potentiometer to serve as the r-f bypass capacitor, or r-f filter as it is often called.

However, this capacitor will not be connected in the circuit at present, since it also will be used in aligning the receiver.

The audio signal developed across the potentiometer is coupled through a 0.005-mfd capacitor to the grid of the 6SQ7 audio voltage amplifier stage.

Step 2. Wiring the Circuit

Your second detector circuit should be wired according to the schematic diagram of Figure 14 with the parts placed as illustrated in the pictorial diagram of Figure 15.

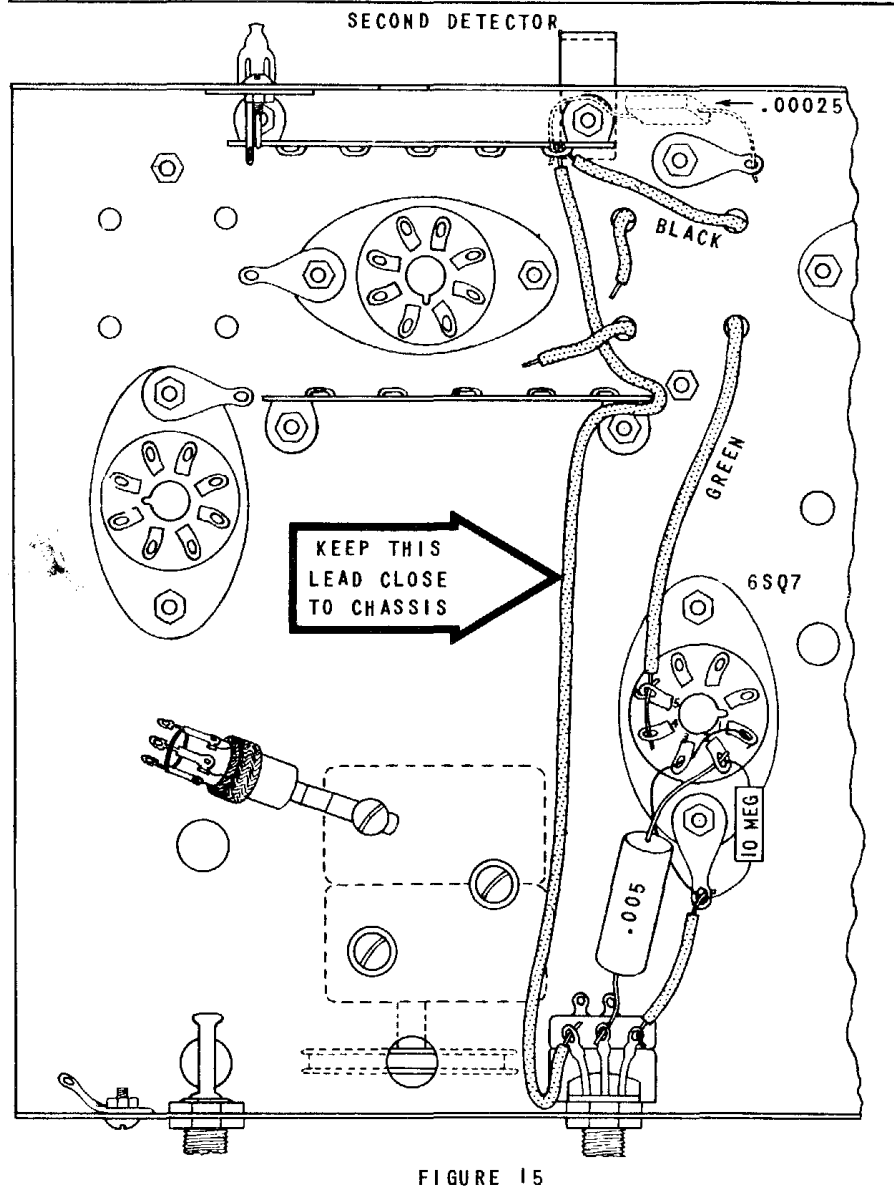

FIGURE 15

One point which should be emphasized concerning the wiring of this circuit (the i-f amplifier, and the converter stage) is that the leads should be arranged as shown in the photograph of Figure 11 as much as is practical.

If the leads from the i-f transformers are not properly arranged oscillation may result due to feedback.

- In this particular circuit the green lead should be connected directly to the pin number 5 of the 6SQ7 tube socket and any excess length should be cut off.

- Similarly, the black lead should be connected directly to the nearest terminal of the five-lug terminal strip as shown in Figure 15.
- This lead should be made as short as possible.
- Likewise the length of hookup wire connected from this terminal on the five-lug terminal strip to the left terminal of the potentiometer should be against the chassis for its entire length.

In order that this lead will be held against the chassis it should be passed between the mounting bracket of the other terminal strip and its mounting bolt as illustrated. This will hold the lead tightly against the chassis. After you have wired your second detector circuit check it carefully against the schematic diagram and the pictorial diagram.

NOTE: Do not connect the 0.00025-mfd capacitor shown dotted in Figures 14 and 15

Step 3. Point-to-Point Resistance Measurements

Make point-to-point resistance measurements on your 6SQ7 socket as it is now wired. Record your readings in the spaces provided in Table 8.

POINT-TO-POINT RESISTANCE MEASUREMENTS CHASSIS GROUND TO FOLLOWING POINTS:									
PIN NO.		1	2	3	4	5	6	7	8
6SQ7	YOUR READING								
	UEL READING	0	10 MEG	0	500K	500K	300K	0	0

Step 4. Voltage Measurements

Since there is no d-c voltage from the power supply connected to the diode detector circuit, point-to-point voltage measurements will not be required on this circuit.

Step 5. Checking the Operation of your Circuit

Since there is no i-f signal available at present, the rectifying action of your second detector cannot be checked at this time. However, the continuity of your wiring can be checked very easily.

- With the 5Y3, 6F6, and 6SQ7 tubes in the sockets, energize your power supply.

- After allowing the appropriate time for the tube warm-up, touch your finger to the blade of your screwdriver and touch the tip of the blade to pin number 2 of the 6SQ7 tube socket.
- This is the same check which was made in the preceding Part and a loud hum should be heard indicating that the audio amplifier section is working properly.
- Now touch the tip of the screwdriver blade to the number 4 or number 5 pin of the 6SQ7 tube socket.
- Once again a hum should be heard in the output of the receiver and the volume of this hum can be controlled by varying the volume control.

If Figure 14 is referred to, it can be seen that this check indicates the continuity of the wiring of your second detector circuit.

Discussion

The diode detector circuit used in this superheterodyne receiver is employed since a relatively strong signal will be applied from the i-f amplifier and the diode detector can handle such a signal without overloading. The fidelity of the diode detector is very good, thereby enabling the receiver to produce a signal with a reasonably low degree of distortion.

- The diode detector acts as a half-wave rectifier circuit developing a pulsating d-c voltage across the 0.5-megohm potentiometer.
- The 0.00025 pfd bypass capacitor filters the r-f component leaving only the audio component present across this resistor.
- This signal is coupled through the 0.005 mfd capacitor to the grid of the first audio amplifier.

Answer Test Question Number 5 at the end of the experiment.

PART VI

The I-F Amplifier

The i-f amplifier serves the purpose of increasing the magnitude at the intermediate frequency signal in a superheterodyne receiver. The intermediate frequency signal is the result of the heterodyning action of the converter stage and has a frequency equal to the difference between the incoming signal frequency and the frequency of the local oscillator.

The modulation present on the incoming signal is also superimposed on the i-f frequency signal. The correct intermediate frequency for this receiver is approximately 456 KHz.

The tuned circuits for this amplifier are formed by the i-f transformers, each of which consists of a tuned primary circuit and a tuned secondary circuit. Small mica compression type capacitors are used to achieve the tuning. These tuned circuits provide the necessary selectivity so that the desired station may be received and the unwanted stations rejected.

Step 1. Analyzing the Circuit.

Figure 16 shows the schematic diagram of the i-f amplifier stage.

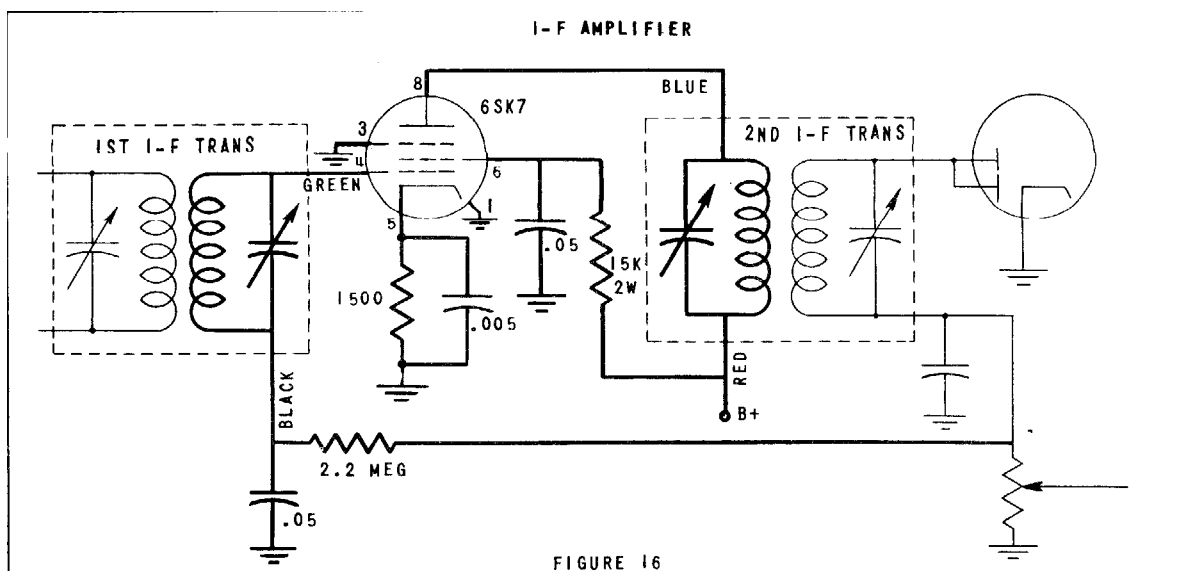

FIGURE 16

- The pentode tube, type 6SK7, is employed.
- The output signal from the i-f amplifier is transformer coupled to the second detector stage that has already been wired.
- The input signal to the i-f amplifier is transformer coupled from the converter stage.
- The plate circuit of the i-f amplifier is operated from the full B+ potential and a 15,000-ohm, 2 watt, dropping resistor is used to lower the screen voltage for this stage.
- A 0.05-mfd capacitor connected between the screen grid and ground places this electrode at r-f ground potential.
- The suppressor grid and shield of this tube are grounded.

- The variable bias used in this amplifier stage is furnished by the automatic volume control circuit, while fixed bias is obtained by use of a 1500 ohm resistor and a 0.005 mfd condenser connected in the cathode circuit.

It will be noted that the complete grid circuit consists of the path from the grid of the 6SK7 tube through the secondary winding of the input transformer, to the junction of the 0.05 mfd capacitor and 2.2 megohm resistor.

The opposite end of the 2.2-megohm resistor connects to the volume control in the second detector circuit.

The voltage present on the top of the volume control in the second detector circuit is a pulsating DC voltage. The amplitude of this voltage is determined by the amplitude of the signal applied to the second detector.

The 2.2 megohm resistor and 0.05 mfd capacitor act as an audio filter circuit and at the junction of these two components only a negative d-c signal is present.

This negative voltage is proportional to the average of the signal applied to the second detector stage. In other words, when a strong signal is applied to the input of the receiver a relatively high voltage will be present across the 0.05 mfd AVC filter capacitor.

If a weak signal is applied to the receiver, a small DC voltage will be present across this capacitor. In this way it can be seen that the voltage present across this capacitor varies in accordance with changes in the strength of the signal arriving at the receiver input.

This AVC voltage is used as bias on the 6SK7 IF amplifier stage. If a strong input signal is received this relatively strong bias voltage will reduce the gain of the i-f amplifier stage thereby reducing the output signal. However if a weaker signal is received the AVC bias voltage will be lower thereby allowing the i-f amplifier to amplify the signal to a greater degree. In this manner the output from the receiver will be relatively constant regardless of the strength of the input signal. Through this means the volume of the signal is controlled automatically and the term automatic volume control is applied to the circuit producing the bias voltage that accomplishes these results.

Step 2. Wiring the Circuit

The pictorial wiring diagram of the i-f amplifier and AVC circuit is given in Figure 17.

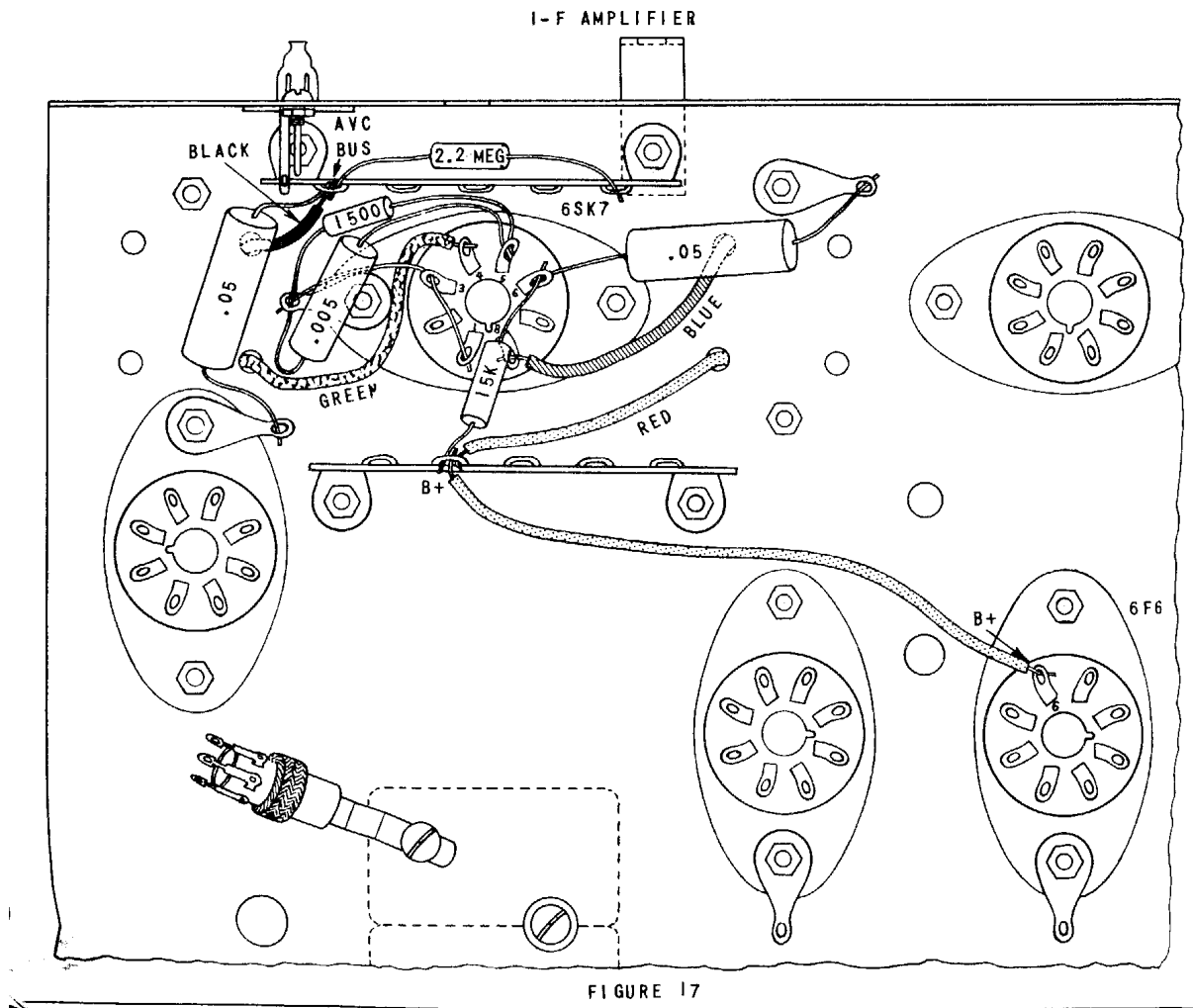

- In connecting this circuit be sure that the leads to the i-f transformers are connected as directly as possible and any excess length of these leads should be cut off.
- This also is particularly important concerning the 0.05 mfd screen grid bypass capacitor connected from pin number 6 of the 6SK7 tube socket to the grounding soldering lug.

Wire your circuit very carefully following the schematic diagram of Figure 16, referring to the pictorial diagram of Figure 17 and the photographic view of the bottom of the chassis as illustrated in Figure 11. Double-check your wiring carefully to make sure that you have made no mistakes.

Step 3. Point-to-Point Resistance Measurements

Make point-to-point resistance measurements on the 6SK7 i-f amplifier stage and record your readings in the spaces provided in Table 9.

TABLE 9

POINT-TO-POINT RESISTANCE MEASUREMENTS CHASSIS GROUND TO FOLLOWING POINTS:									
PIN NO.		1	2	3	4	5	6	7	8
6SK7	YOUR READING								
	UEL READING	0	0	0	2 MEG	1500	500K	0	500K

If your values do not correspond closely to those listed in Table 9 for the circuit at UEL check carefully to determine the cause.

Step 4. Point-to-Point Voltage Measurements.

Before inserting the 6SK7 tube in the socket make the point-to-point voltage measurements to fill in the blanks in the top portion of Table 10.

TABLE 10

POINT-TO-POINT VOLTAGE MEASUREMENTS CHASSIS GROUND TO FOLLOWING POINTS:											
PIN NO.		1	2	3	4	5	6	7	8		
6SK7 SOCKET <u>WITHOUT</u> TUBE	YOUR READING	0	OMIT					OMIT			
	UEL READING	0		0	0	0	310		315		
6SK7 SOCKET <u>WITH</u> TUBE	YOUR READING										
	UEL READING	0		0	0	15	240		275		

If your readings check with those obtained at UEL, insert the 6SK7 tube in the socket and make the voltage measurements to fill the lower portion of this table.

NOTE: The 6SQ7, 6F6, and 5Y3 tubes should be in their sockets when making these measurements.

Step 5. Preliminary Check of the I-F Amplifier

Touch your finger to the blade of your screwdriver and scrape the tip of the screwdriver across the grid terminal (pin number 4) of the 6SK7 tube socket with the receiver volume control turned to its maximum clockwise position. If your i-f amplifier is operating properly a scratching or humming sound should be heard in the loudspeaker.

Discussion

- The i-f amplifier of the superheterodyne receiver employs a tuned grid circuit and a tuned plate circuit. For this reason, a pentode tube is employed to minimize the feedback from plate to grid. If a triode tube were used this stage would oscillate as a tuned-grid tuned-plate oscillator and would therefore not amplify the i-f signal.
- The .05-mfd capacitor connected between pin number 6 of the i-f amplifier tube socket and ground places the screen grid of the tube at r-f ground potential, thereby making it effective in reducing the interelectrode capacity of the tube.
- It should be emphasized however that there are other means of feedback that may produce undesired coupling between the plate circuit and the grid circuit of this IF amplifier.
- One of the chief sources of coupling is due to stray capacity present between the leads of the transformer connected in the output circuit and the leads of the transformer connected in the input circuit. This is the reason why in the wiring process, it was emphasized that the i-f transformer leads should be as short as possible.
- If long leads are used for these connections, an unduly large amount of stray capacity will be introduced into the circuit and the IF amplifier may "go into oscillation".

Answer Test Question Number 6 at the end of the experiment.

PART VII

Preliminary Wiring of the Converter Stage

The complete schematic diagram for the converter stage used in this superheterodyne receiver is illustrated in Figure 18.

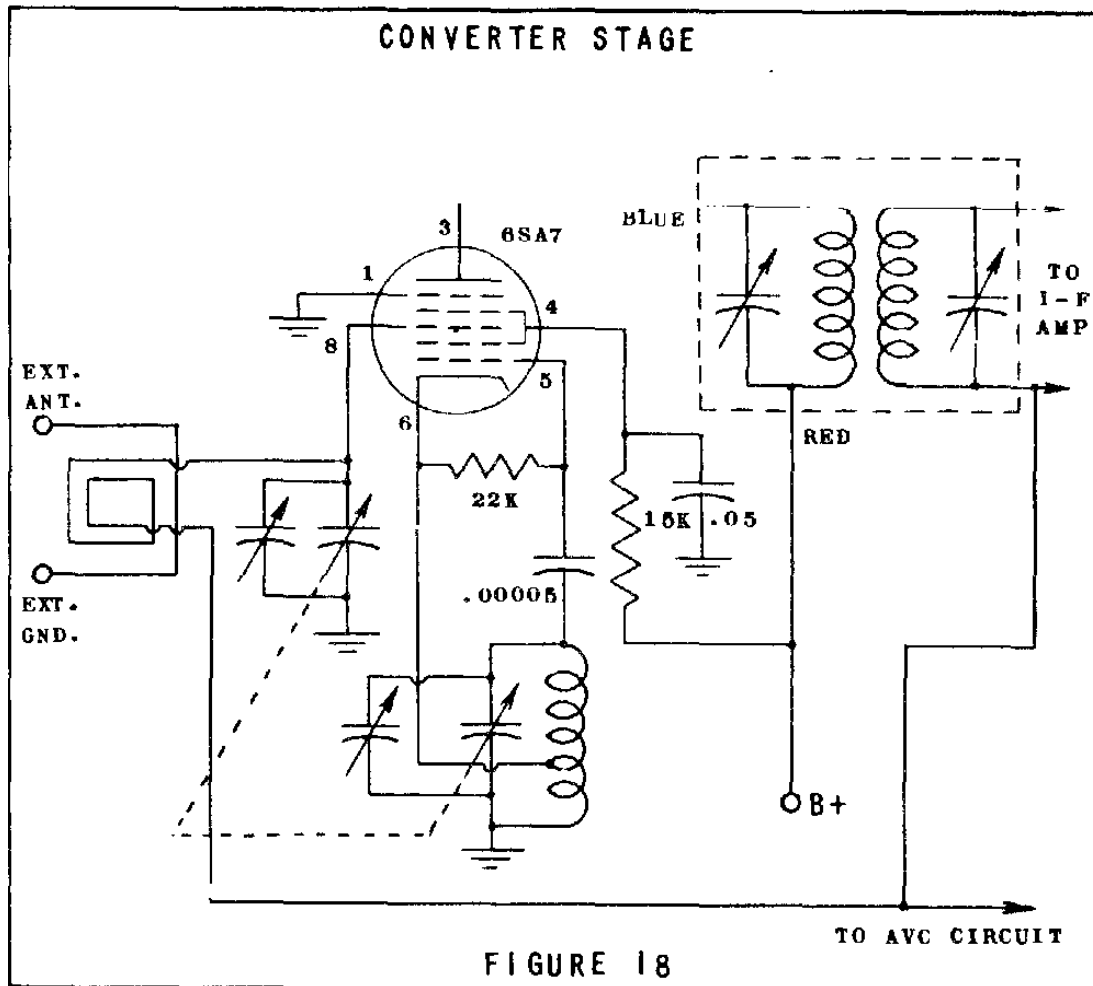

- The r-f input signal is coupled from the loop antenna to pin 8, grid number 3 of the 6SA7 tube.
- The cathode plus grid number 1, and grids number 2 and number 4, form a Hartley oscillator circuit (the LO).
- This circuit is tuned by the oscillator section of the tuning condenser and generates a signal that is 456 kilocycles higher in frequency than the incoming signal.
- In the converter stage this signal is mixed with the incoming signal and, because the action of the circuit is over a nonlinear portion of the characteristic curve,

heterodyne detection occurs, producing the sum and difference frequencies of these two signals in the output.

- The tuned circuit present in the plate circuit of the converter stage is tuned to the difference frequency - which is 456 kilo-cycles in this case.
- This difference frequency signal contains the modulation characteristics of the input signal and forms the i-f signal applied to the i-f amplifier.

The 15,000-ohm resistor employed as the dropping resistor in the circuit of the number 2 and number 4 grids is the 15,000-ohm resistor that was installed in the preceding part of the experiment. Likewise, the 0.05-mfd capacitor that places these grids at r-f ground potential was installed in the previous Part.

One of the requirements for proper operation of a superheterodyne receiver is that the various circuits are properly aligned.

To correctly align the i-f stages of a superheterodyne receiver some form of signal generator is required. In the normal servicing of radio receivers a signal generator consisting of a specially designed instrument for this purpose is employed. However, to achieve the results in this experiment a very practical signal generator and one that is readily available will be used.

The oscillator section of the converter stage is a signal generator. That is, this circuit generates an r-f signal. To correctly align the i-f stages it will only be necessary to adjust the frequency of this oscillator to 456 KHz and use this signal to secure proper alignment in the i-f stages. To secure these results, a preliminary method of wiring will be employed with the 6SA7 converter stage. Upon the completion of this preliminary wiring the 6SA7 stage will not be operating as a converter. Instead, this stage will be operated as a signal generator. The stage will be used in this manner to align the IF transformers after which it will be changed so that it will again form the converter stage illustrated in Figure 18.

Step 1. Analyzing the Circuit of the 6SA7 I-F Signal Generator

The circuit arrangement used to convert the 6SA7 tube into the i-f signal generator is illustrated in Figure 19.

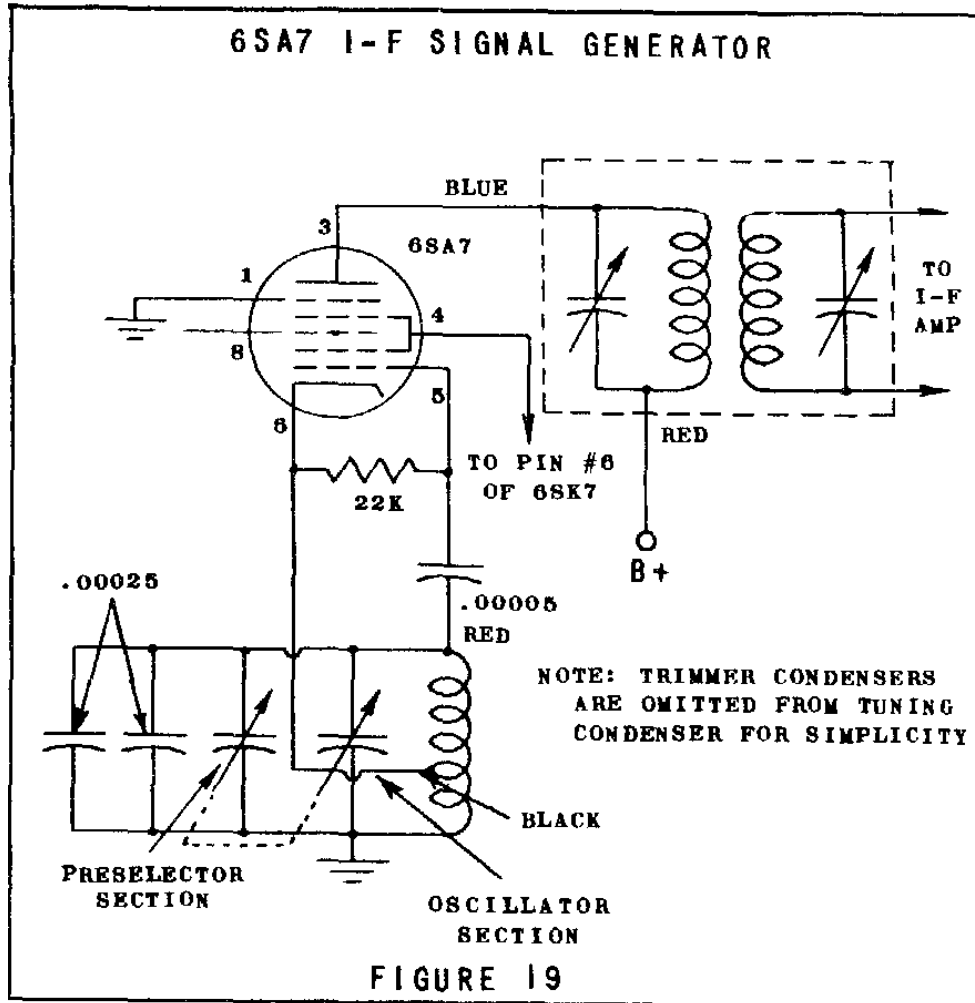

If this diagram is compared to Figure 18 it will be found that the oscillator circuit is unchanged except that a higher value of capacity is connected across the oscillator coil.

In Figure 19, in addition to the oscillator section of the tuning condenser connected across this coil, it will be found that the preselector section of the tuning condenser and two 0.00025 mfd capacitors are connected in parallel.

This large total value of capacity is necessary in the circuit so that resonance will occur at 456 KHz. With the oscillator section of the tuning condenser alone in the circuit, the frequency range of the oscillator is from approximately 1000 to 2150 KHz. The added capacity lowers the r-f signal from this oscillator to 450 KHz.

The oscillator is electron coupled to the plate circuit that consists of the primary of the first i-f transformer.

Step 2. Wiring the Circuit

The circuit of Figure 19 should be wired following the general parts layout illustrated in Figure 20.

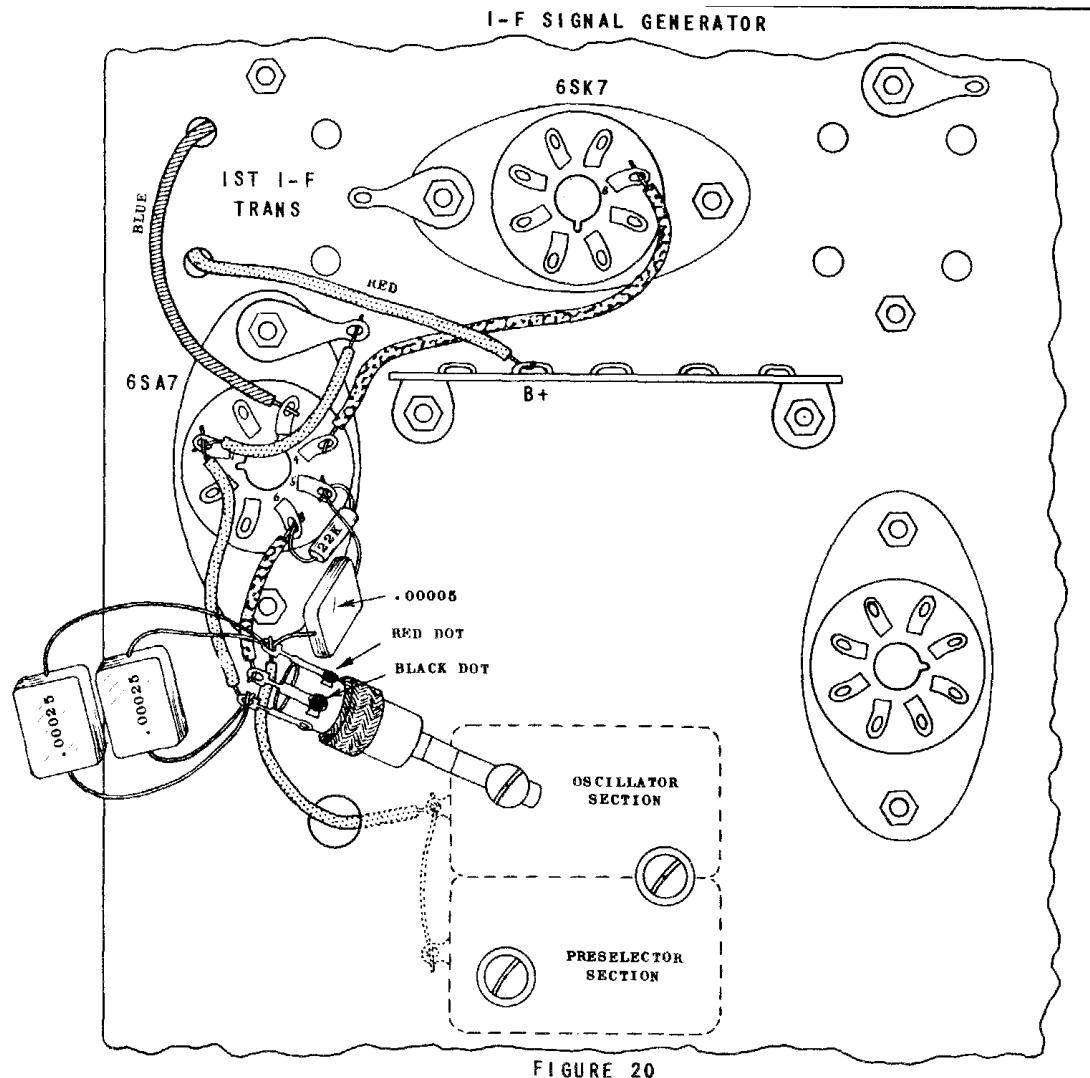

- In performing this wiring operation, be sure that the red i-f transformer lead is located close to the chassis and is no longer than necessary.
- Similarly the blue IF transformer lead should run directly to pin number 3 of the 6SA7 tube socket.
- In addition route the lead from pin number 4 of the 6SA7 tube socket to pin number 6 of the 6SK7 tube socket as close to the chassis as possible.
- The leads of the 0.00005 mfd capacitor should be shortened so that it can be mounted directly between the terminal of the oscillator coil with the red dot and pin number 5 of the 6SA7 tube socket.

Lab 7A Superhet Radio

- However, the connection of the two 0.00025 mfd capacitors from the oscillator coil terminal with the red dot to the unmarked terminal is only a temporary connection and the leads of these capacitors should not be cut off.
- Install the lead from the oscillator coil terminal with the red dot to the oscillator section of the tuning condenser as a permanent connection.
- However, the lead between the oscillator section and the preselector section of the tuning condenser is a temporary connection and will be removed presently.
- After completing this wiring, check your circuit very carefully against the schematic diagram of Figure 19 and the pictorial diagram of Figure 20 to make sure that no mistakes in wiring have been made.

Step 3. Point-to-Point Resistance Measurements

Take point-to-point resistance measurements on the 6SA7 tube socket and record your resistance values in the spaces provided in Table 11.

TABLE 11

POINT-TO-POINT RESISTANCE MEASUREMENTS CHASSIS GROUND TO FOLLOWING POINTS:									
PIN NO.		1	2	3	4	5	6	7	8
6SA7	YOUR READING								
	UEL READING	0	0	500K	500K	21K	0	0	∞

Step 4. Point-to-Point Voltage Measurements

Before inserting the 6SA7 tube in the socket make point-to-point voltage measurements on this tube socket, recording the values of voltage measured in the spaces provided in the top portion of Table 12.

TABLE 12

POINT-TO-POINT VOLTAGE MEASUREMENTS CHASSIS GROUND TO FOLLOWING POINTS:										
PIN NO.		1	2	3	4	5	6	7	8	
6SA7 SOCKET <u>WITHOUT</u> TUBE	YOUR READING		OMIT					OMIT		
	UEL READING	0		275	240	0	0		0	
6SA7 SOCKET <u>WITH</u> TUBE	YOUR READING									
	UEL READING	0		275	110	-5V*	0		0	

*NOTE: USE 75V D.C. RANGE

If your voltages agree with those obtained at UEL, insert the 6SA7 tube in the socket and make the point-to-point voltage measurements to fill in the blank spaces in lower portion of Table 12.

Pin number 5 of the 6SA7 connects to the oscillator grid electrode. If you measure a bias voltage at this point it indicates that the oscillator is functioning. If the oscillator is working properly we will be able to proceed with the alignment of the i-f stages.

Discussion

- The oscillator section of the 6SA7 has been wired to function as a signal generator for the purpose of aligning the tuned circuits of the i-f transformers.
- This oscillator will be tuned to 456 KHz to enable correct alignment to be obtained. Let us re-emphasize the fact that such an arrangement is not normally employed in aligning a broadcast receiver. As pointed out in the theory assignment concerning alignment, an external signal generator is normally employed. However, the source of signal in this case is quite stable since it is electron coupled to the remainder of the circuit and will produce very satisfactory alignment of the i-f stages of this receiver.

Answer Test Question Number 7 at the end of the experiment.

PART VIII

Aligning the I-F Stages

In aligning the i-f stages, all four of the tuned circuits (two in the 1st i-f transformer and two in the 2nd i-f transformer) should be adjusted to the correct i-f frequency of 456 KHz.

To obtain a clear understanding of the aligning process used, examine Figure 21.

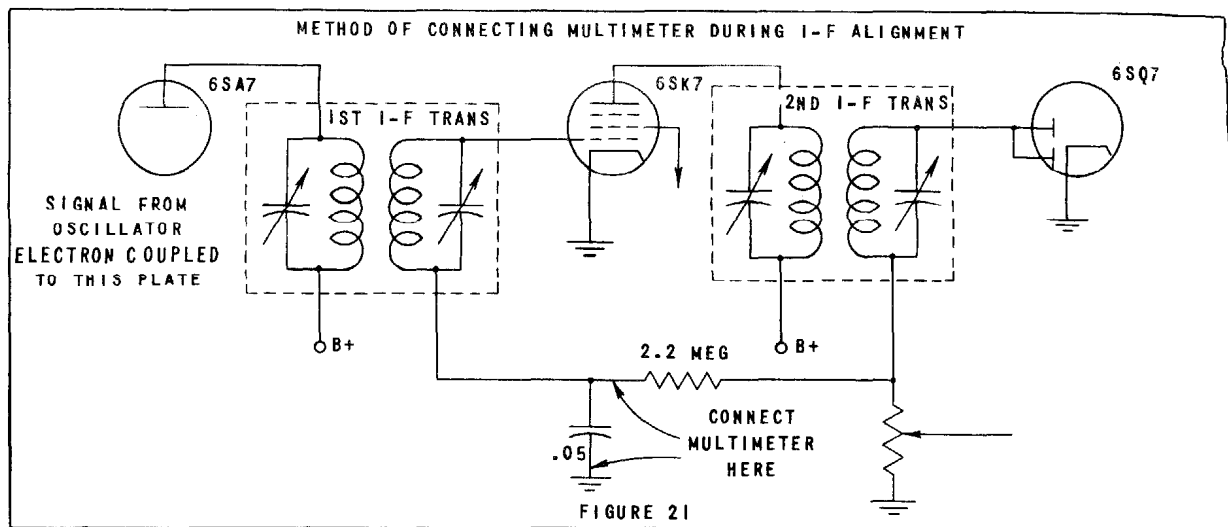

This figure shows a partial schematic circuit of the receiver, indicating only those parts in which we are now interested.

- The signal from the oscillator section of the 6SA7 is electron coupled to the plate circuit.
- The tuned circuit formed by the primary of the first i-f transformer and its parallel trimmer capacitor is the plate load for this stage.
- If the oscillator is operating on the i-f frequency and this trimmer is adjusted to resonance, the gain obtained will be maximum.
- Similarly, adjusting the trimmer capacitor in the secondary circuit of the first i-f transformer will allow a maximum signal to be applied to the grid of the 6SK7.
- When the trimmer in the primary circuit of the 2nd i-f transformer is adjusted to maximum, the i-f amplifier will be operating with maximum gain and adjustment of the

secondary trimmer of the 2nd i-f transformer will allow a maximum signal to be applied to the 6SQ7 tube.

As mentioned previously, the 6SQ7 circuit is arranged so that it also acts as an automatic volume control circuit.

- When the input signal to this circuit is maximum, a maximum d-c voltage will be developed across the 0.05 mfd AVC filter capacitor.
- In addition, the very strong signal applied to the 6SK7 circuit, causes grid current to flow, thereby, developing a d-c voltage across the 2.2 megohm resistor.

If this circuit is analyzed it can be seen that the correct tuning of the i-f transformers will be indicated by:

- a maximum DC voltage present across the 0.05 mfd AVC filter capacitor.
- In this arrangement, then, the multimeter will be used to measure the voltage present across the 0.05 mfd AVC filter capacitor,
- the signal generator will be adjusted to 456 KHz and
- the trimmers on the i-f transformers will be adjusted for a maximum reading on the voltmeter.

Analyze this circuit carefully to make sure that you understand the process taking place.

Step 1. Connecting the Multimeter as an Alignment Indicator

Connect your multimeter as a 150-volt D.C. meter by placing the rotary selector switch in the 150 volt D.C. position, the A.C.-D.C. switch in the D.C. position, the black test lead in the COM jack, and the red test lead in the VOLTS jack.

Connect the red test lead to the chassis and the black test lead to the junction of the 2.2 megohm AVC filter resistor and the 0.05 mfd AVC filter capacitor.

- See Figure 17. This junction is made at the terminal on the 5 lug terminal strip nearest the phono jack and is labeled AVC BUS.
- With the meter connected in this manner the negative voltage present across the 0.05 mfd capacitor will be measured.
- Temporarily connect a lead between pin number 5 of the 6SK7 tube socket and the adjacent ground lug.

Step 2. Adjusting the Oscillator to 456 KHz

- Turn on your receiver and turn the tuning condenser until the plates are fully meshed (maximum capacity).

Lab 7A Superhet Radio

- Adjust the pointer until it is exactly on 55 on the dial.
- Tighten the adjusting screws on both the preselector and oscillator trimmer capacitors mounted on the main tuning condenser.
- This will set these two capacitors at their maximum capacity position.
- Now rotate the tuning knob until the dial pointer is exactly half way between 60 and 70 on the dial.
- At this setting the frequency of your temporary signal generator will be approximately 456 KHz.

Step 3. Aligning the I-F Stages

With your multimeter connected as outlined in Step 1 and your temporary signal generator operating on 456 KHz as explained in Step 2, proceed with the i-f alignment.

- Adjust the trimmers on the 1st i-f transformer with your small screwdriver for maximum reading on the multimeter.
- Adjust these trimmers slowly making sure that you leave them in the position that gives you maximum reading.
- Now adjust the trimmers on the 2nd i-f transformer for a maximum reading on the meter.
- It is necessary to repeat these adjustments to get the best possible alignment.
- Now remove the temporary lead previously connected between pin number 5 of the 6SK7 tube socket and ground.

Record the maximum voltage you measured across the 0.05 mfd capacitor when your circuit is properly aligned: _____

In the circuit at UEL a reading of approximately 70 volts was obtained.

Discussion

The alignment procedure used in this part of the experiment provides a very convenient method for correctly resonating the tuned circuit of the i-f transformers to the correct frequency.

The oscillator section of the 6SK7 tube furnishes a strong signal for use in the alignment and, the peak obtained when tuning the trimmers is sharp, providing a good adjustment.

Answer Test Question Number 8 at the end of the experiment.

PART IX

Completing the Receiver Wiring

Figure 22 shows the schematic diagram of the converter stage as it should be wired for operation in the superheterodyne receiver.

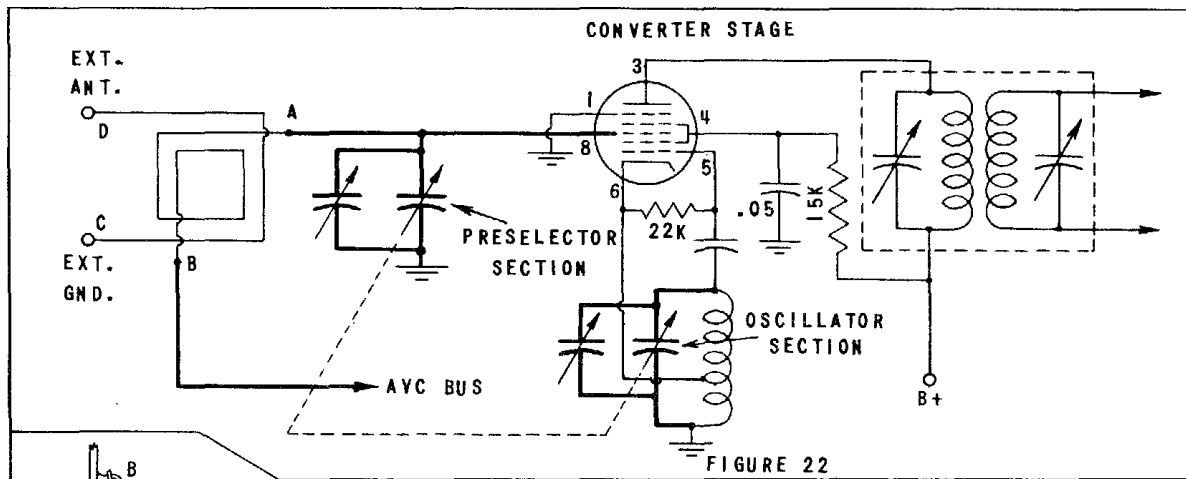

This circuit is the same as that of Figure 18 and needs no further explanation at this time. Only those components shown dark in this figure require changing.

It will be noted in Figure 22, as well as in many of the other figures, that terminals C and D of the loop antenna are labeled external antenna and ground. However, these external antenna connections will not be required unless you live in a location very remote from broadcast stations. In other words, if the normal table model radio receiver will work in your locality without an external antenna, this superheterodyne receiver should also operate satisfactorily.

Step 1. Wiring the Circuit

To connect the converter stage in the proper manner, first

- remove the two 0.00025 mfd capacitors connected across the oscillator coil.
- Also disconnect the short length of hookup wire connected between the terminal of the oscillator section and the terminal of the preselector section of the tuning condenser.

Lab 7A Superhet Radio

- Do not remove the lead connected between the oscillator section of the tuning condenser and the oscillator coil terminal with the red dot.
- Mount the loop antenna as shown in Figure 23 and connect a lead from terminal B of the antenna through the hole in the rear of the chassis to the AVC bus terminal on the five-lug terminal strip.
- Connect another length of hookup wire from terminal A across the top of the chassis to the terminal of the preselector section of the tuning condenser.
- Connect a length of hookup wire from pin number 8 of the 6SA7 tube socket to the opposite terminal on the preselector section of the tuning condenser as shown in Figure 23.

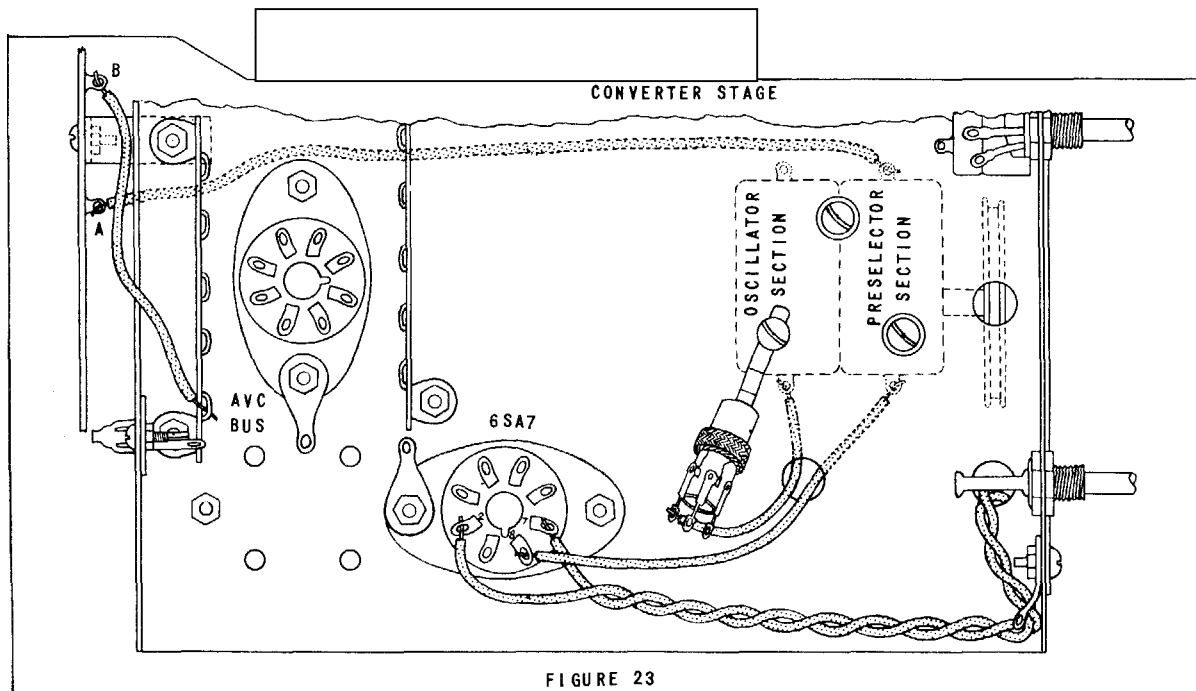

This completes the wiring of the converter stage.

Now the two 0.00025 mfd capacitors should be mounted.

- One of the capacitors serves as the r-f filter for the second detector (see Figure 14).
- Mount this capacitor as shown by the dotted capacitor in Figure 15.
- The other 0.00025 mfd capacitor serves as a high-frequency bypass capacitor across the grid load resistor of the power amplifier (see Figure 2).

- To mount the 0.00025 mfd capacitor see Figure 10. This capacitor should be connected between pin number 5 of the 6F6 tube socket and the grounding soldering lug as indicated by the dotted capacitor in this figure.

The pilot lamp holder should now be mounted on the dial. The manner of doing this is illustrated in Figure 24.

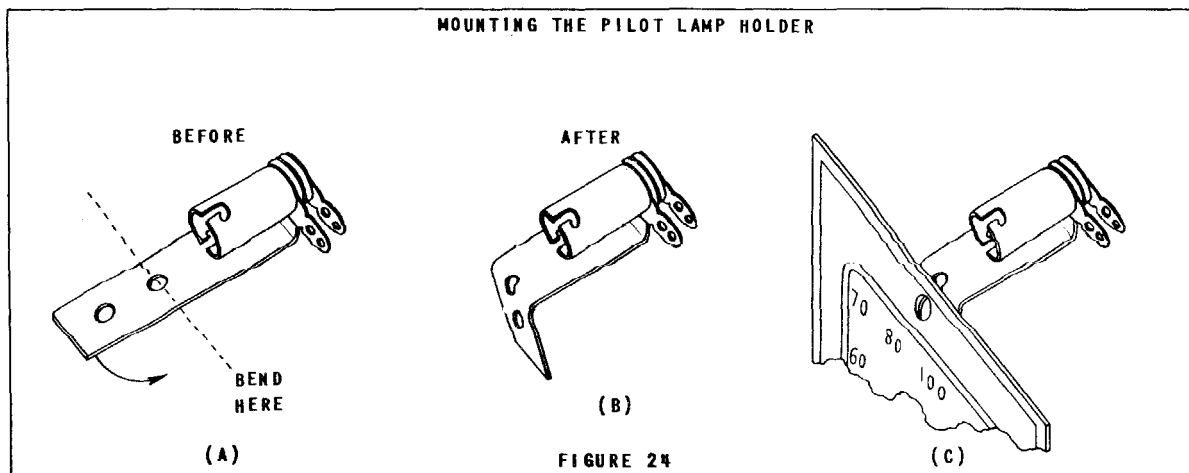

In Figure 24(A) the pilot lamp holder is shown as it was supplied to you. Use a pair of pliers to bend this mounting bracket at a right angle at the point indicated in Figure 24(A) forming a mounting bracket as illustrated in Figure 24(B). Then mount the pilot lamp holder behind the dial plate with a 6/32 machine screw as shown in Figure 24(C).

To wire the pilot lamp holder, take two lengths of hookup wire approximately 1 foot in length and twist these leads together. Push back the insulation on one set of ends and connect to pin number 2 and 7 of the 6SA7 tube socket as illustrated in Figure 23. Route this pair of twisted leads along the edge of your chassis to the front corner as indicated, then bend the leads and pass them through the dial cable hole as shown. To hold these leads secure so that they will not get tangled in the dial cord, bend the soldering-lug terminal shown in Figure 23 against the wires holding them securely.

Run the leads straight up from the dial hole against the back of the dial plate. At the top edge of the dial plate bend a right angle in the wire, cut off the leads to the proper length and solder to the two pilot lamp solder terminals. After you have soldered these connections bend the hookup wire so that it will be held securely against the front panel. Insert the pilot lamp in the holder.

The only other circuit in the receiver that remains to be connected is the phono input circuit. Reference to Figure 2 will show that the center terminal of the phono input jack should connect through a 0.02 mfd capacitor to the "top" end of the volume control. The outside terminal of the phono input jack connects to ground.

Figure 25 gives a pictorial view of the manner in which this jack should be connected.

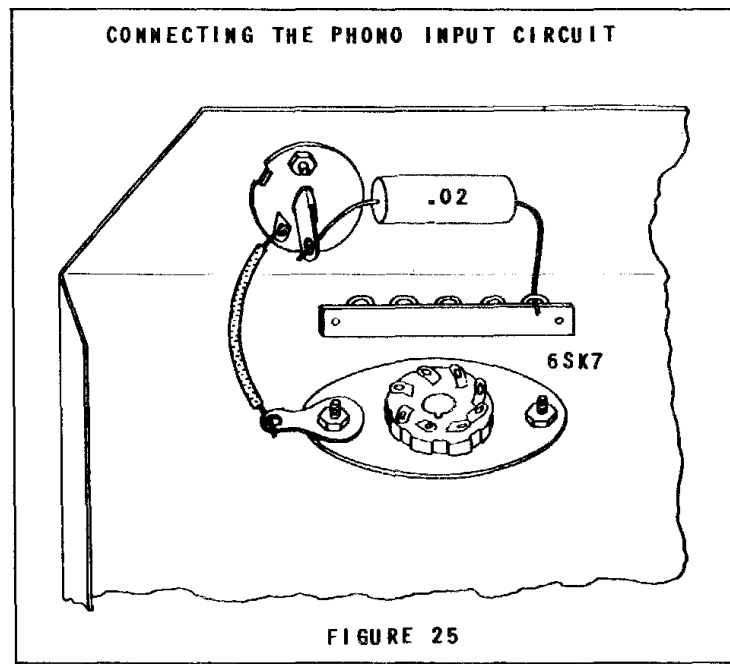

The outside terminal of the jack connects directly to the grounded soldering lug located at the edge of the 6SK7 tube socket. The center terminal of the phono input jack connects through a 0.02 mfd capacitor to the end terminal of the nearest five-lug terminal strip. If the wiring is checked it will be seen that this terminal is connected directly to the volume control by a length of hookup wire.

Upon completion of this wiring your superheterodyne receiver circuit should be the same as the complete schematic diagram of Figure 2.

Before proceeding with the alignment of the preselector section of this receiver, carefully check your entire wiring against the schematic diagram of Figure 2.

Be sure that you are very thorough in this operation, paying particular attention to checking the last additions in the wiring that have been made. After you are completely satisfied that your circuit is wired according to the schematic diagram of

Figure 2 you are ready to proceed with the next Part of the experiment.

Discussion

The complete superheterodyne receiver has now been wired. You should be able to analyze the complete schematic diagram of Figure 2 and determine in your own mind exactly how each circuit functions and the part played by each component in the circuit. If you cannot do this you should plan to review very completely the subject material on the circuits that are in doubt so that your understanding of this circuit will be complete. You are also advised to practice drawing the schematic diagram of Figure 2 until you can draw the diagram from memory. This is important since this superheterodyne receiver is similar to many of the superheterodyne receivers on the market.

This circuit is superior to the great majority of AC-DC receivers since the 6.3 volt heater type tubes give much longer trouble-free service than do the higher voltage heater type tubes in the AC-DC receivers.

Also, the power supply in this receiver delivers a much higher voltage than that obtainable from the normal transformerless supply, thereby producing a higher gain circuit.

Answer Test Question Number 9 at the end of the experiment.

PART X

The Preselector Alignment

The i-f stages of your receiver have been aligned to 456 KHz, and to complete the alignment procedure it will only be necessary to align the preselector section and the oscillator section of the receiver.

To accomplish this proceed as follows:

- Tune your receiver to a station near the low-frequency end of the band whose frequency is known. If you do not know the frequency your local stations, refer to the radio program section of your local newspaper.
- Hold the dial drum and move the pointer to the proper point on the dial. For example, let us assume that the station to which you have tuned your receiver is known to be on 600 KHz. However, let us further assume that your dial pointer is between 55 and 60. (Note that one of the zeros has been dropped from the various numbers on the

dial and 55 indicates 550 KHz, 100 equals 1000 KHz, 140 equals 1400 KHz, etc.) In this case you should leave your receiver tuned to that particular station and move the dial pointer until it is directly on the correct frequency or on 600 KHz in the example cited.

- Now tune in a station of known frequency near the high-frequency end of the band. If this station does not come in at the proper point on the dial, adjust the *oscillator trimmer* capacitor until it does. If there is any question concerning which of the trimmer capacitors is the *oscillator trimmer*, refer to Home Laboratory Experiment No. 5, Figure 6(A).
- Next adjust the *preselector trimmer* for maximum volume of the signal.
NOTE: It may be difficult to obtain a peak when making this adjustment unless a distant station is being received. On a strong local station the AVC voltage may keep the volume at a constant level.
- Now check the dial settings for other stations of known frequency. If your dial is correct on the high-frequency end and the low frequency end, it should be correct for the other points on the dial. If the stations do not come in at the proper point repeat the above alignment procedure.

Step 1. Point-to-Point Voltage Measurements

After you have your receiver operating you should make the point-to-point voltage measurements necessary to fill the blank spaces provided in Table 13.

TABLE 13

POINT-TO-POINT VOLTAGE MEASUREMENTS CHASSIS GROUND TO FOLLOWING POINTS:									
PIN NO.		1	2	3	4	5	6	7	8
5Y3	YOUR READING	0	360	0	OMIT	0	OMIT	0	360
	UEL READING	0	360	0	OMIT	0	OMIT	0	360
6F6	YOUR READING	0	OMIT	290	300	0	300	OMIT	30
	UEL READING	0	OMIT	270	275	0	275	OMIT	25
6SQ7	YOUR READING	0	0	0	0	0	125	OMIT	OMIT
	UEL READING	0	0	0	0	0	110	OMIT	OMIT
6SK7	YOUR READING	0	OMIT	0	0	5	100	OMIT	300
	UEL READING	0	OMIT	0	0	7	100	OMIT	270
6SA7	YOUR READING	0	OMIT	300	100	-5	0	OMIT	0
	UEL READING	0	OMIT	270	100	-11*	0	OMIT	0

*USING 150V D.C. RANGE

Answer Test Question Number 10 at the end of the experiment.

Use of Phono Input Circuit

The phono input circuit incorporated in this receiver is designed for use with a crystal type of phonograph pickup. Figure 26 shows the schematic diagram of this circuit with the phono pickup connected.

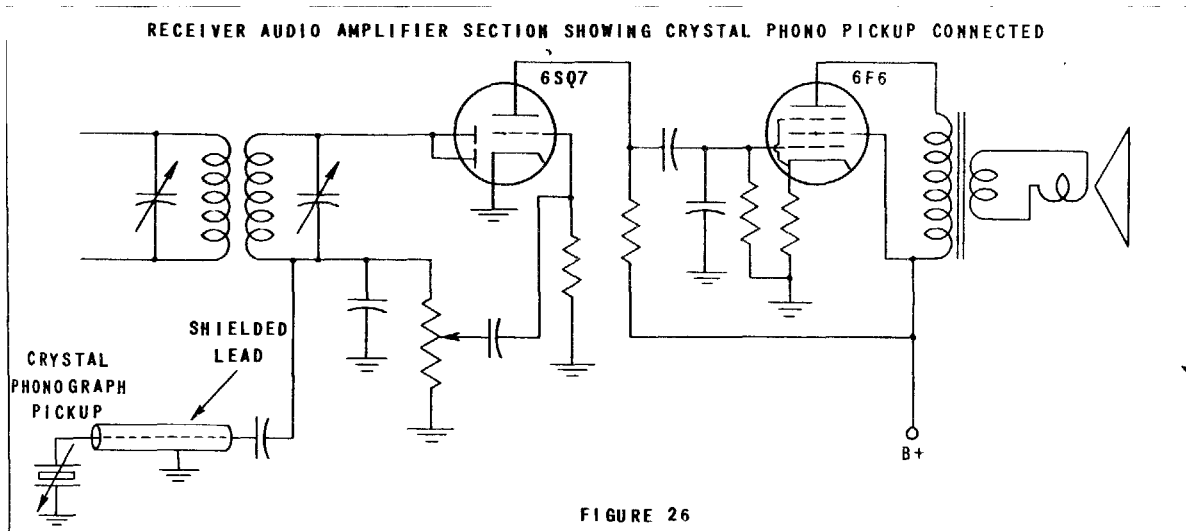

It will be noted that the 6SQ7 voltage amplifier and the 6F6 power amplifier are used to amplify the output from the crystal pickup to a level satisfactory for operation of a loudspeaker.

To use the phono input circuit, it is only necessary to connect the crystal pickup of an electric phonograph to the phono input plug, then insert the plug into the phono input jack, turn on the receiver and tune it to a point on the dial where no station is heard.

The volume of the output signal can be adjusted by the volume control on the receiver.

In almost all cases the lead from a crystal phono pickup consists of a small, shielded lead. The inner conductor of this lead should be connected to the center terminal of the phono plug. Figure 27 is a detailed drawing indicating the manner in which the lead from a crystal pickup should be soldered to this plug.

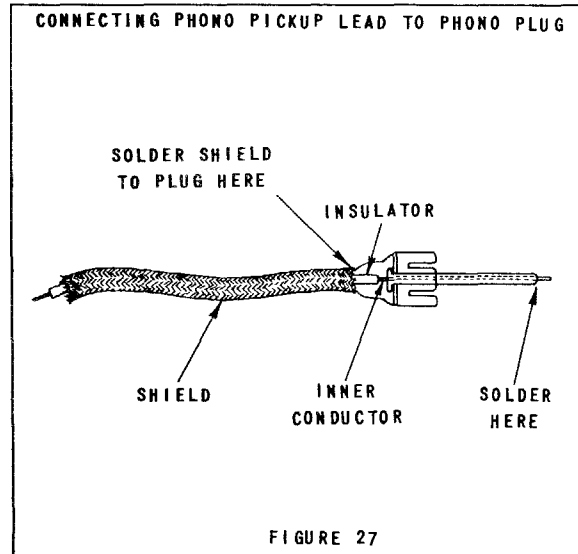

The end of the shield should be tinned before attempting to solder it.

Summary of Entire Experiment

This experiment has provided you the opportunity to construct and analyze the operation of all the circuits in a complete superheterodyne receiver. These circuits are typical of the various types of circuits found in millions of superheterodyne receivers now in use. After constructing the receiver you should have very little difficulty understanding the operation of similar circuits in any superheterodyne receiver.

If your superheterodyne receiver operates satisfactorily submit the Test Questions at the end of the experiment for grading.

Home Laboratory Experiment No. 7B will be sent to you after you have submitted a few more assignments. In H.L.E. 7B the manner in which various defects affect a receiver will be demonstrated. For example, the affect produced by an open bypass capacitor or a shorted coupling capacitor will be demonstrated. These demonstrations should enable you to quickly locate the source of trouble in a defective receiver.

-30-